

LAVA STONE

Kitchen - Bathroom - Wellness

SECOND EDITION

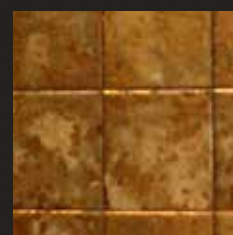
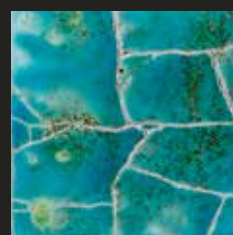
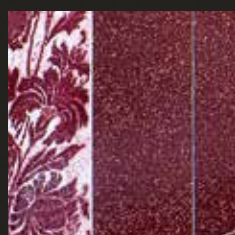
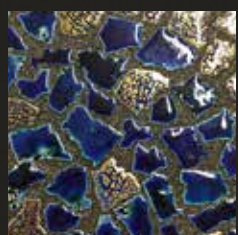

ACQUARIODUE PORTFOLIO BOOK KITCHEN BATHROOM WELLNESS COLLECTION



© Acquario Due

via 1° maggio 31/33
35030 Bastia di Rovolon
Padova - Italy
+39 (049) 9910777
+39 (049) + 9914101

info@acquarioceramiche.com
www.acquarioceramiche.com
www.facebook.com/AcquarioDue
www.twitter.com/AcquarioDue

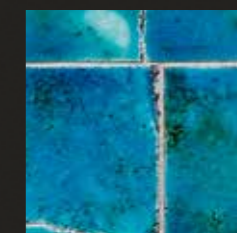
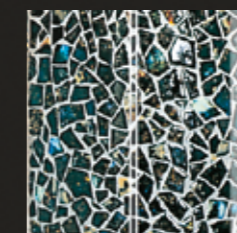
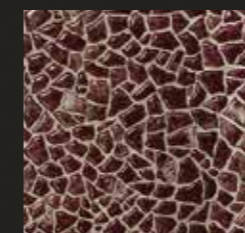
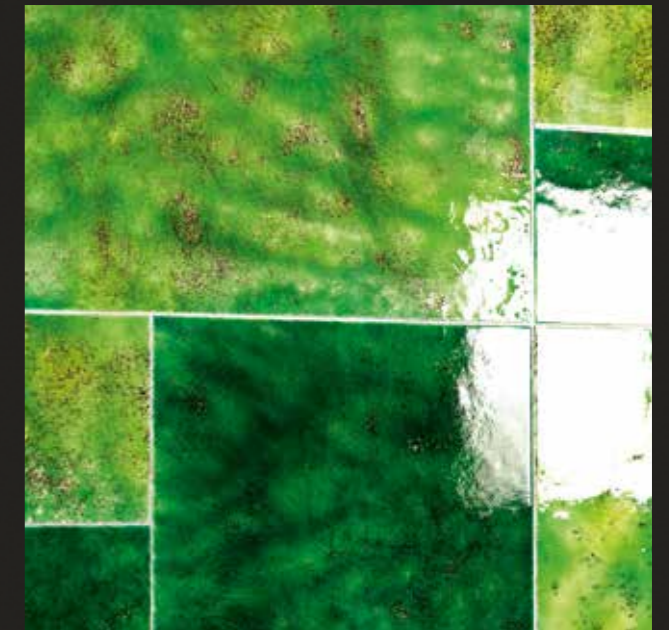
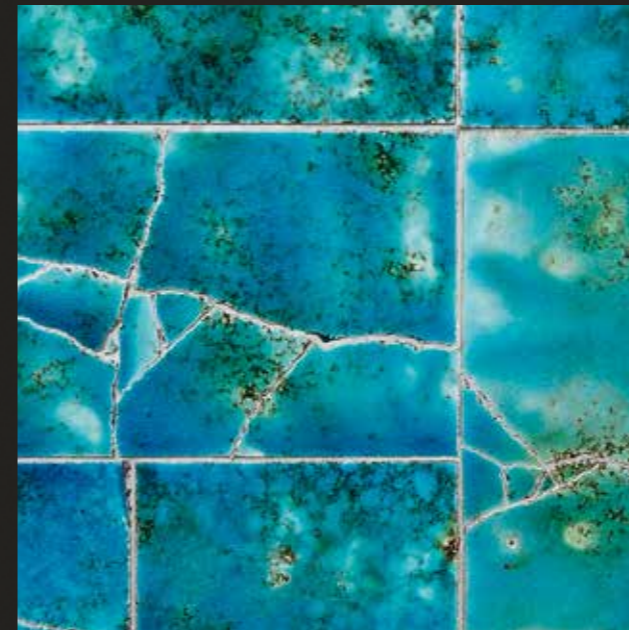

LAVA STONE

LAVA STONE

è una raccolta di ambienti bagno caratterizzati dallo stile ACQUARIO DUE, il nostro stile.

Stile unico ed inimitabile che fortemente ha contribuito, nel corso della propria attività, alla crescita dell'immagine della lavorazione artistico-artigianale della ceramica per pavimenti e rivestimenti MADE in ITALY. L'intera produzione è caratterizzata dal sapiente uso delle materie e dei colori che solo l'esperienza del fondatore Zancanella Federico, ora coadiuvato dai figli, ha saputo coniugare, realizzando superfici destinate ad ambienti unici, in grado di stimolare il Desiderio e di appagare il Piacere di possederli. Sensazioni stimulate dall'incontro con le materie ACQUARIO DUE. Un incontro che muove al tatto nell'irresistibile sfiorare le ceramiche in bicottura, la Pietra Lavica smaltata dell'Etna, il Grès, la Porcellana, carichi dei colori effusi dai Vetri di Murano e dagli smalti di antica scuola e della migliore Tradizione Ceramica ITALIANA. Colori ricchi di sfumature, venature e riflessi che inebriano la vista trasportando l'immaginazione.

LAVA STONE

is a collection of bathrooms characterized by ACQUARIO DUE's Style.

A unique and unequalled style that has strongly contributed, during the course of the company's activity, to the growth of the artistic-handmade work's image of floor's and wall's ceramic MADE in ITALY. The entire production is characterized by the wise use of materials and colors that only the experience of the Chef founder Mr. Zancanella Federico, now supported by his sons, is able to conjugate, by realizing wonderful surfaces destined to unique places that are able to spur the Pleasure and satisfy the Desire of possessing them. The match of ACQUARIO DUE's materials stimulates unrestrainable sensations that move to the irresistible touch of skimming the surface of double-firing Ceramic, glazed Etna's Lava Stone, Grès, Artistic Porcelain, rich in colors bestowed by the Glass of Murano and Glazes of the antique ceramic school and from the best Italian Ceramic Tradition. Colors full of shadings, veinings and reflections that inebriate the eyes by carrying away the Imagination.



ЛАВА СТОН

Это сборник ваннных помещений

Охарактеризованных особым стилем ACQUARIO DUE, нашем стилем.

Наш особый и неповторимый стиль, внес свою важную и неоценимую лепту в развитие всей сферы ручной работы по керамике в таких направлениях как напольное покрытие и отделка MADE in ITALY. Все производство охарактеризовано опытом использования уникальных материалов и техник их нанесения создателем компании Дзанканелла Федерико, сейчас место Федерико заняли его дети. Федерико сумел создать продукт желаемый самими требовательными клиентами, пробуждая в них фантазию и желание обладать неповторимым стилем! Чувства вызываемые при встречи с продуктами ACQUARIO DUE: встреча которая тебя трогает, открывая для себя коллекции керамики с двойным обжигом, каменную лаву с вулкана Этна, настоящие кристаллы Венецианского стекла Мурано, неповторимые и насыщенные цвета эмали, все это стало возможным реализовать благодаря исторической школой прикладных искусств керамики. Невероятные цвета и оттенки, в крапины и отражения заставляют мечтать!

LAVA STONE

est une collection de Salles de Bains caractérisées par le style ACQUARIO DUE, notre Style.

Style unique et inimitable qui a fortement contribué, pendant le cours de son activité, à la croissance de l'image de la fabrication artistique-artisanale de la céramique pour le sols et les murs, MADE in ITALY. La totalité de la production est caractérisées par l'utilisation adroite des matériaux et des couleurs que seulement l'expérience du fondateur Federico Zancanella, maintenant secondé par ses fils, a réussi à combiner, en créant surfaces qui sont destinées à des environnements uniques, capables de stimuler le Désir et satisfaire le Plaisir de les posséder. Sensations stimulées par le rencontre avec les matériels ACQUARIO DUE. Une rencontre qui se déplace au Toucher, en l'irrésistible glissement de la surface de la céramique en double-feu, de la pierre de lave de l'Etna émaillée, du Grès, de la Porcelaine, chargés des couleurs effusés par les Verres de Murano et les émaux de l'ancienne école et de la meilleure tradition céramique italienne ! Les couleurs riches de nuances, de veinages et de reflets, enivrent la vue et transportent l'Imagination.



La materia si trasforma e si apre per un viaggio in profondità: mari ondeggianti, eclettiche trasparenze, giochi di luce riflessi in cristalli di ghiaccio, esaltanti atmosfere sprigionate da minerali preziosi. Colori che stimolano il gusto e l'olfatto, sprigionano sapori, odori e profumi caratteristici della nostra Terra. Colori che fusi nella materia assumono forma e dimensione per diventare finiture ed arredo della stanza da bagno. Queste immagini esprimono il nostro Stile che ci caratterizza nel vastissimo mondo della ceramica, fornendo un chiaro esempio di ciò che Noi siamo e vogliamo continuare ad essere. Una fucina di idee, materie e prodotti al di là di ciò che è già stato fatto; sapienti creazioni artigianali interpretano la scelta di non rispondere a canoni ripetitivi o industriali. Lavorazioni di ceramiche e colori dalla qualità unica e dalla bellezza inimitabile esprimono il nostro Progetto; perché il nostro obiettivo è creare soluzioni di pregio per ambienti il cui valore rimane nel tempo.

The matter is transformed and opens for a journey in the glaze's deepness: waving seas, eclectic transparencies, plays of light that are reflected in iced crystals, exciting atmospheres given off by the precious minerals. Colors that spur the taste and the sense of smell that release flavors, smells and fragrances that are characteristic of our Earth. Colors that, melted in the matter, take shapes and dimensions to become finishings and designs of the Bathroom. These images express our Style that characterize us in the enormous Ceramic World by giving a clear example of what we are and what we want to continue to be. ACQUARIO DUE is a forge of ideas, materials and products, out of the existing schemes; the wise handmade creations explain our choice to be different and not answer to repeated or industrial rules. From this forge rise ceramic's workings and colors of unique quality and inimitable beauty, giving voice to our Project, because our Aim is to create solutions of quality for places which value stay in time.

Раскрывая все свойства материала, мы предлагаем вам пуститься в необыкновенное путешествие: бушующее море, бесконечную прозрачность, игру цветов и отражений ледовых кристаллов, в глубокую атмосферу драгоценных минералов. Используемые нами цвета, передают запахи наших земель, преобразуемые в конечную форму в виде отделочных материалов для ваших помещений. Эти представления передают наш стиль в работе с керамикой, что показывает кем мы являемся и кем мы хотим стать! Большой сундук идей, материалов и мастерства, позволяющих не повторяться, а создавать новые веяния! Обработка керамики, краски высочайшего уровня и неповторимой красоты, знаменуют наш Проект: основная цель которого, создание решений для мест сохраняющих свою ценность во времени!

La matière se transforme et s'ouvre à un voyage au plus profond : mers ondoyantes, transparences éclectiques, jeux de lumière qui se reflètent dans les cristaux de glace, exaltantes atmosphères émises par les minéraux précieux. Couleurs qui stimulent le goût et l'odorat, qui dégagent saveurs, odeurs et parfums typiques de notre terre. Couleurs qui ont été fondus dans la matière et ont pris la forme et la taille pour devenir finitions et design dans la Salle de Bains. Ces images expriment notre Style, qui nous caractérise dans le vaste monde de la céramique, en offrant un clair exemple de ce que nous sommes et ce que nous voulons continuer à être. Un creuset d'idées, de matériaux et de produits au-delà de ce qui a déjà été fait ; créations artisanales qualifiées interprètent le choix de ne pas répondre aux canons industriels et répétitifs. La fabrication de céramique par les couleurs d'une qualité unique et de beauté incomparable, expriment notre Projet ; parce que notre But est de créer des solutions de qualité pour des milieux dont le valeur reste dans le temps.

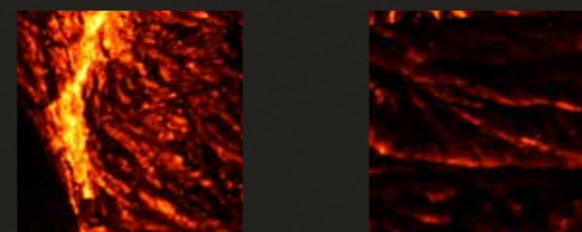
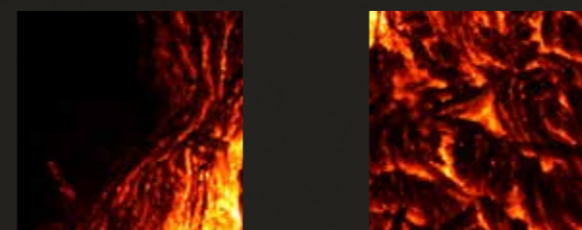
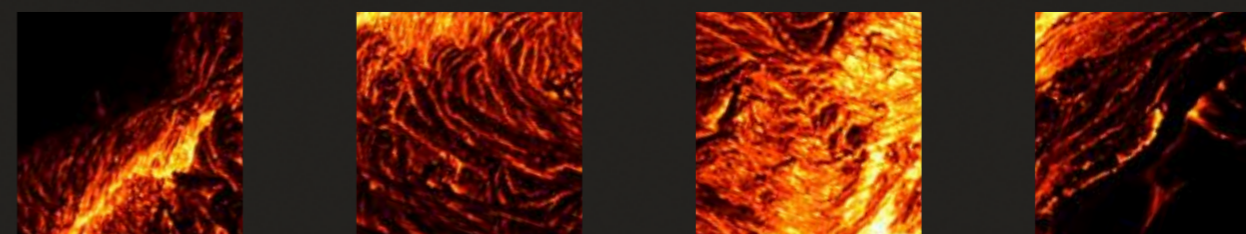

SiO₂ - 45-52%
 Al₂O₃ - 14%
 CaO - 10%
 FeO - 5-14%
 MgO - 5-12%
 alkali - 2-6%
 TiO₂ - 0,5-2%

HOTEL HA(A)ÏTZA - PYLA SUR MER

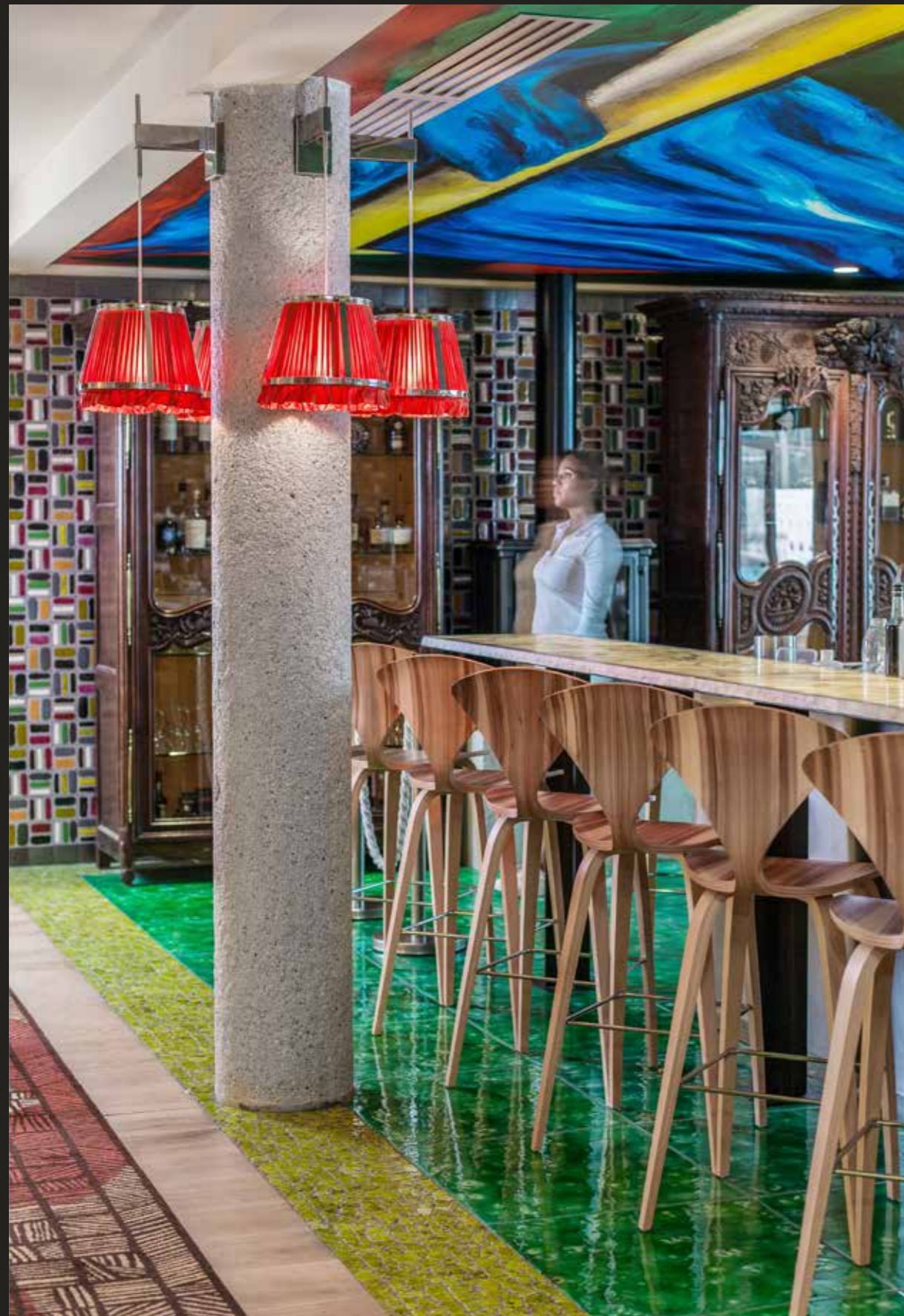

PROJECT BY STARCK+

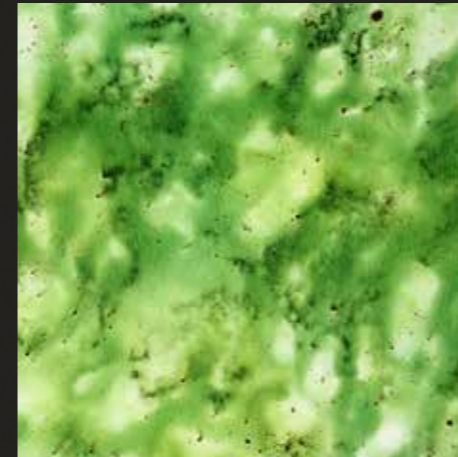

60x60-1
Canaletto Verde Chiaro Pr. 86 m²



30x30 Opus 3-6 cm
Canaletto Giallo Pr. 99 m² loose pieces (sfuso)
Pr. 102 m² on net (su rete)



CANALETTO AZZURRO



80x160 Canaletto Azzurro - LAVASTONE
Casa FDN _Napoli_Arch. Flavio Di Fiore/X-Studio Architettura

CANALETTO AZZURRO



80x160 Canaletto Azzurro - LAVASTONE
Casa FDN _Napoli_Arch. Flavio Di Fiore/X-Studio Architettura

CANALETTO CIELO



20x60 MP01 White Diamond S.Metalli Preziosi CERAMIC Pr.68 M²

1,8x60 Canaletto Cielo LAVASTONE Pr.42 Pcs

60x60 Canaletto Cielo LAVASTONE Pr.86 M²

CANALETTO



Le lastre in pietra lavica canaletto vengono ottenute dopo un lungo processo di lavorazioni artigianali. Dall'estrazione della pietra lavica dell'Etna si passa al taglio a misura della lastra e successivamente si procede alla prima smaltatura con ingobbio che esalta gli ossidi e i metalli presenti nella composizione della pietra stessa. Eseguita questa prima smaltatura si procede alla prima cottura per poi continuare la produzione con la seconda fase di smaltatura con applicazione di speciali cristalline a grosso spessore e semina di vetri di Murano che verranno vetrificati in forno alla temperatura di 980°C.

The Lava stone slabs, in Canaletto colors, are obtained after a long handicraft process. From the extraction of Etna's (volcano) lava stone, the slab must be cut at measurement and then we can proceed with the 1st glazing with engobes that exalt oxides and metals content in the compositions of the rock. After the 1st glazing, we can go on with the 1st cooking, and then continue the production with the 2nd phase of glazing. The 2nd phase consist in the application of specials crystalline of big thickness and the seeding of Murano glasses, that will vitrified in the oven at 980°C.

Плиты из каменной лавы каналетто проходят длительный ручной процесс изготовления. В начале каменная лава добывается с залежей на вулкане Этна, затем проходит процесс нарезания на плиты необходимых размеров, последующим шагом является нанесение на поверхность плит оксидов и металлов содержащихся в самой лаве. После первой обработки лавы и обжига ее в печи переходим ко второму этапу, где наносятся специальные крупные кристаллы и крошка из стекла Мурано, далее плиты повторно помещаются в печ с температурой в 980°C. градусов Цельсия.

Les plaques en pierre de lave, dans les couleurs Canaletto, sont obtenues après un processus de longue artisanat. De l'extraction de la pierre de lave de l'Etna (volcan), la plaque doit être coupé à mesure, puis nous pouvons procéder au 1ère émaillage avec des engobes qui exaltent les oxydes et les métaux contenus dans la composition de la roche. Après le 1er émaillage, nous pouvons faire la 1er cuisson, puis poursuivre la production avec la 2ème phase d'émaillage. La 2ème phase consiste en l'application de spéciales cristallines de grande épaisseur et l'ensemencement des verres de Murano, qui vitrifieront dans le four à 980°C.

WHITE DIAMOND



MP01 White diamond metalli preziosi é una ceramica in pasta bianca smaltata ottenuta con 8 applicazioni artigianali di smalti sovrapposti e amalgamati con componenti vegetali che ne determinano la struttura. L'ultima applicazione prevede un aerografo di mica argentata che ne esalta la qualità della struttura

MP01 Белый алмаз ценные металлы это: белая керамика, нанесения эмали происходит в ручную 8 этапами с добавлением натуральных элементов определяющих верхней поверхность. Заключаящей обработкой является нанесения аэрографом серебряной слюды выражающей поверхность плитки.

MP01 White Diamond of Metalli Preziosi collection, is made on white body ceramic tiles and it is obtained through 8 hand-applications of overlying glazes that are mixed with vegetable components to create the structure of the surface. The last application is made with a silver mica that exalt the quality of the surface.

MP01 White Diamond de la collection Metalli Preziosi, est effectué sur des carreaux de céramique en pâte blanche et il est obtenu par 8 applications de main recouvrant les émaux qui sont mélangés avec composants végétaux pour créer la structure de la surface. La dernière application est faite avec la mica d'argent qui exalte la qualité de la surface.

RADICI

“Radici” é il risultato decorativo del materiale naturale . Infatti si ottiene da una lastra in pietra lavica che viene rotta nelle venature più fragili, per poi essere smaltata, cotta e ricomposta su rete.

„Корни”, это результат декорации натуральных материалов. Подобный эффект достигается из плит каменной лавы, которые разбиваются по слабым местам для последующего нанесения эмали, проходит обжиг в печи и наклеивается на сетку.

“Radici” is the decorative result of the natural material. In fact we obtain it from a lava stone slab. We break it in the most fragile veins and we glaze it, then we cook it and we recompose it on net.

«Radici» est le résultat de décoration de la matière naturelle. En fait, nous l'obtenons d'une plaque en pierre de lave. Nous la brisons dans les veines les plus fragiles et nous l'émaillons, nous cuisinons et nous la recomposons sur réseau de fibre céramique.

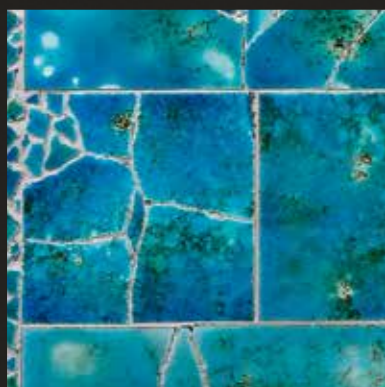

OPUS 3-6 CM

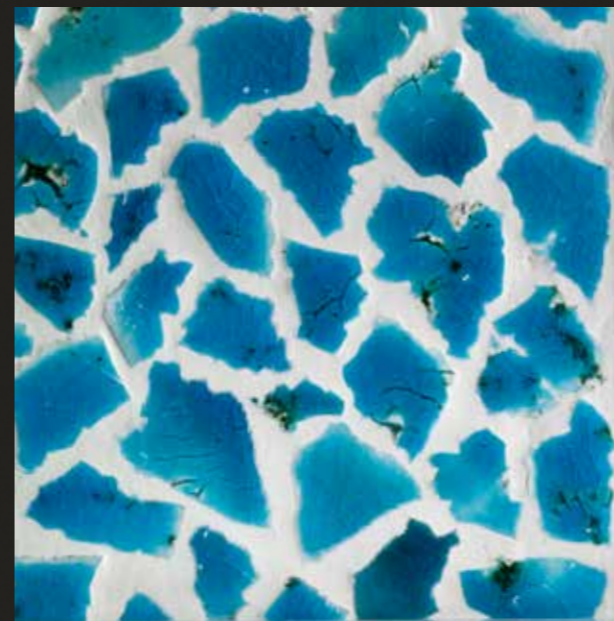

Opus 3-6 cm é il risultato della frantumazione pezzo per pezzo di lastre in pietra lavica spessore 7 mm. Perché 7 mm? Il motivo sta tutto nella miglior frastagliatura del pezzo che lavorato con questo spessore garantisce il miglior risultato estetico oltre ad essere ideale per rivestire superfici curve.

Opus 3-6 cm is the result of the crushing, piece by piece, of big slabs of lava stone thickness 7 mm.

Why 7 mm? The reason lays in the better crushing of every single piece that, worked on this thickness, guarantee the better aesthetic result, and also because it is ideal for the covering of curved surfaces.

Опус 3-6 см. это результат не однородного разбивания куска за кусок каменной лавы толщиной в 7 мм. Почему 7 мм? Основным мотивом является идеальное соотношение толщины и плотности плиты позволяющее дробится при разбивании наилучшего эстетического результата и возможности использования в закругленных деталях.

Opus 3-6 cm est le résultat de l'écrasement, pièce par pièce, de grandes plaques en pierre de lave épaisseur de 7 mm. Pourquoi 7 mm? La raison réside dans le meilleur écrasement de chaque pièce qui travaillé dans cette épaisseur, assure le meilleur résultat esthétique, et aussi parce qu'il est idéal pour le revêtement de surfaces courbes.



60x60 Canaletto Azzurro LAVASTONE Pr.86 M² 60x60 Canaletto Azzurro Radici LAVASTONE Pr.82 Pcs
 30x30 Canaletto Azzurro LAVASTONE Pr.83 M² 30x30 Canaletto Azzurro Radici LAVASTONE Pr.68 Pcs
 30x60 Canaletto Azzurro LAVASTONE Pr.87 M² 30x60 Canaletto Azzurro Radici LAVASTONE Pr.79 Pcs

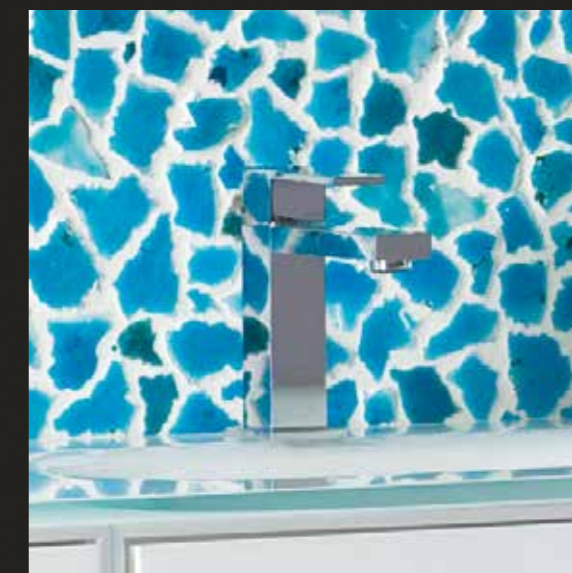
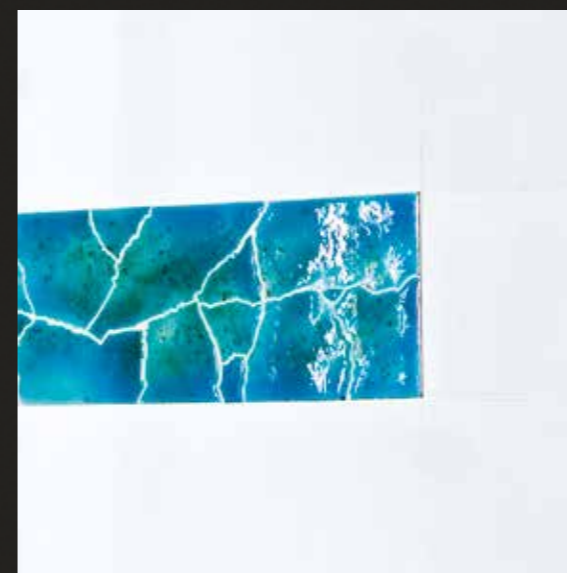

Opus 3-6cm Canaletto Azzurro sfuso (loose pieces) LAVASTONE Pr.99 M²

CANALETTO AZZURRO



20x60 MP01 White Diamond S.Metalli Preziosi CERAMIC Pr.68 M²

5x60 inciso MP01 White Diamond S.Metalli Preziosi CERAMIC Pr.70 M²

5x60 inciso MP31 Gold Turquoise S.Metalli Preziosi CERAMIC Pr.70 M²

20x60 Radici Canaletto Azzurro LAVASTONE Pr.71 Pcs

20x60 Canaletto Azzurro LAVASTONE Pr.88 M²

1,8x60 Canaletto Azzurro LAVASTONE Pr.42 Pcs

Macro Opus 10 - 20 Cm Canaletto Azzurro LAVASTONE Pr.90 M²

Opus 3-6 Cm Canaletto Azzurro LAVASTONE Pr.99 M²

60x60 Canaletto Azzurro LAVASTONE Pr.86 M²



LIBERTA' DI CREARE

Il gioco sta tutto nella modularità tra dei formati che si assemblano l'uno all'altro. Questo consente la massima libertà di progettazione e composizione.

Свобода мысли

Основной смысл свободы мысли заключается в игре различными форматами, цветами и материалами, это позволяет свободно создавать самые смелые проекты и композиции.

FREE TO CREATE

The play is in the modularity of formats that assemble to one another. This thing allows the liberty of design and composition.

LIBRE DE CRÉER

Le jeu est dans la modularité des formats qui s'assemblent les uns aux autres.

Cette chose permet la liberté de conception et de composition.



STONALIZZATO D'OBBLIGO

Caratteristica del materiale naturale è la stonalizzazione, infatti ogni piastrella è differente, garantendo sfumature uniche che fanno di CANALETTO una collezione ineguagliabile.

Il vetro che fonde a 500°C esalta le materie che compongono la pietra fondendo al proprio interno gli ossidi coloranti.

SHADE VARIATION is a MUST

The main characteristic of natural materials is the shade variation, in fact every tile is different and guarantees unique shadings that identify CANALETTO as a peerless collection!

The glass that melts at 500°C exalts the substances that compose the rock, by melting the colored oxides inside it.

Идентичность

Используя натуральный материал, после ручной обработки каждая плитка наделяется не повторимым рисунком, что выделяет коллекцию каналетто из всех других.

LA DIFFERENCE DE NUANCE est un Must

La principale caractéristique de matériaux naturels est la variation de nuance, en fait, chaque carreau est différent et garantie des nuances uniques qui identifient CANALETTO comme une collection hors pair!

Le verre qui fond à 500°C exalte les substances qui composent la roche, par fusion des oxydes de couleur à l'intérieur.





60x60 Canaletto Azzurro / Cielo LAVASTONE Pr.86 M² 30x60 Canaletto Azzurro / Cielo LAVASTONE Pr.87 M²
 60x120 Canaletto Azzurro / Cielo LAVASTONE Pr.86 Pcs 30x30 Canaletto Azzurro / Cielo LAVASTONE Pr.83 M²

E TU DI CHE FORMATO SEI?

Grande formato per la massima espressione della superficie, o piccolo formato che esalta ogni singolo pezzo?
 Dal 10x10 al 60x120 la modularità standard non ha paragoni, per tutto il resto c'è il su misura.

А твой формат каков?

Какой формат выбрать: большой для максимального восприятия или маленький для выражения каждого элемента? От 10x10 до 60x120 мм. стандартные форматы для всех проектов, а для всего остального есть производство по вашим размерам.

AND YOU, WHICH SIZE ARE YOU?

Big format for the maximum expression of the surface, or little format that exalts every single piece?
 From 10x10 cm to 60x120 cm, the standard modularity doesn't have compares, for everything else there is the tailor-made!

ET VOUS, QUELLE TAILLE ÊTES VOUS?

Grand format pour l'expression maximale de la surface, ou petit format qui exalte chaque pièce?
 De 10x10 cm à 60x120 cm, la modularité standard n'a pas comparaison, pour le reste, il y a la réalisations sur mesure!

1 0 X 1 0
 1 5 X 1 5
 2 0 X 2 0
 3 0 X 3 0
 6 0 X 6 0
 6 0 X 1 2 0
 3 0 X 6 0
 2 0 X 6 0
 1 0 X 6 0
 0 5 X 6 0

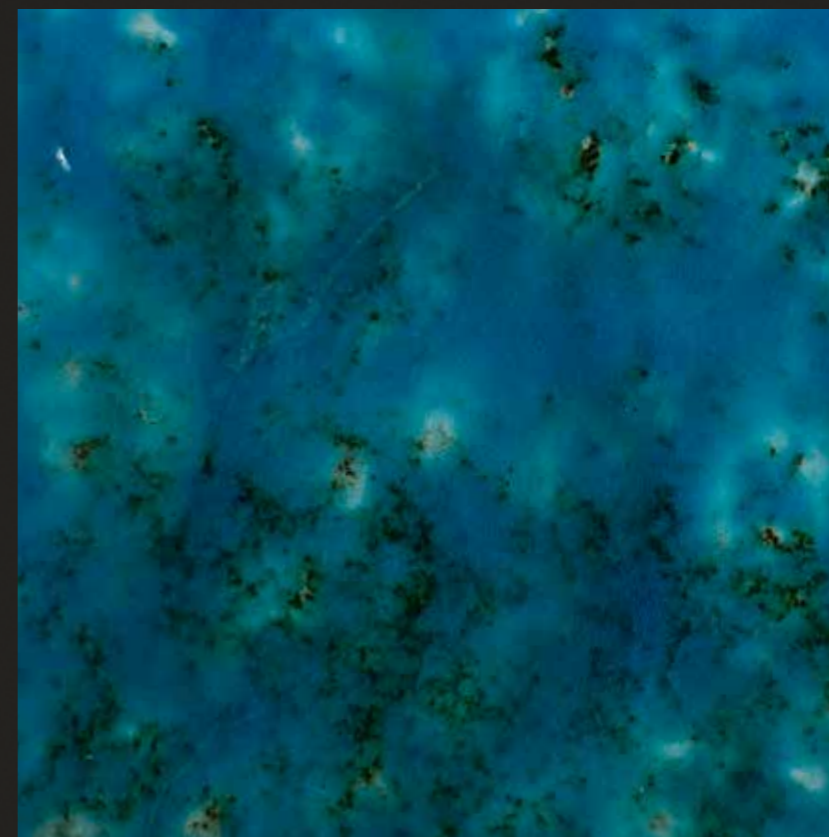

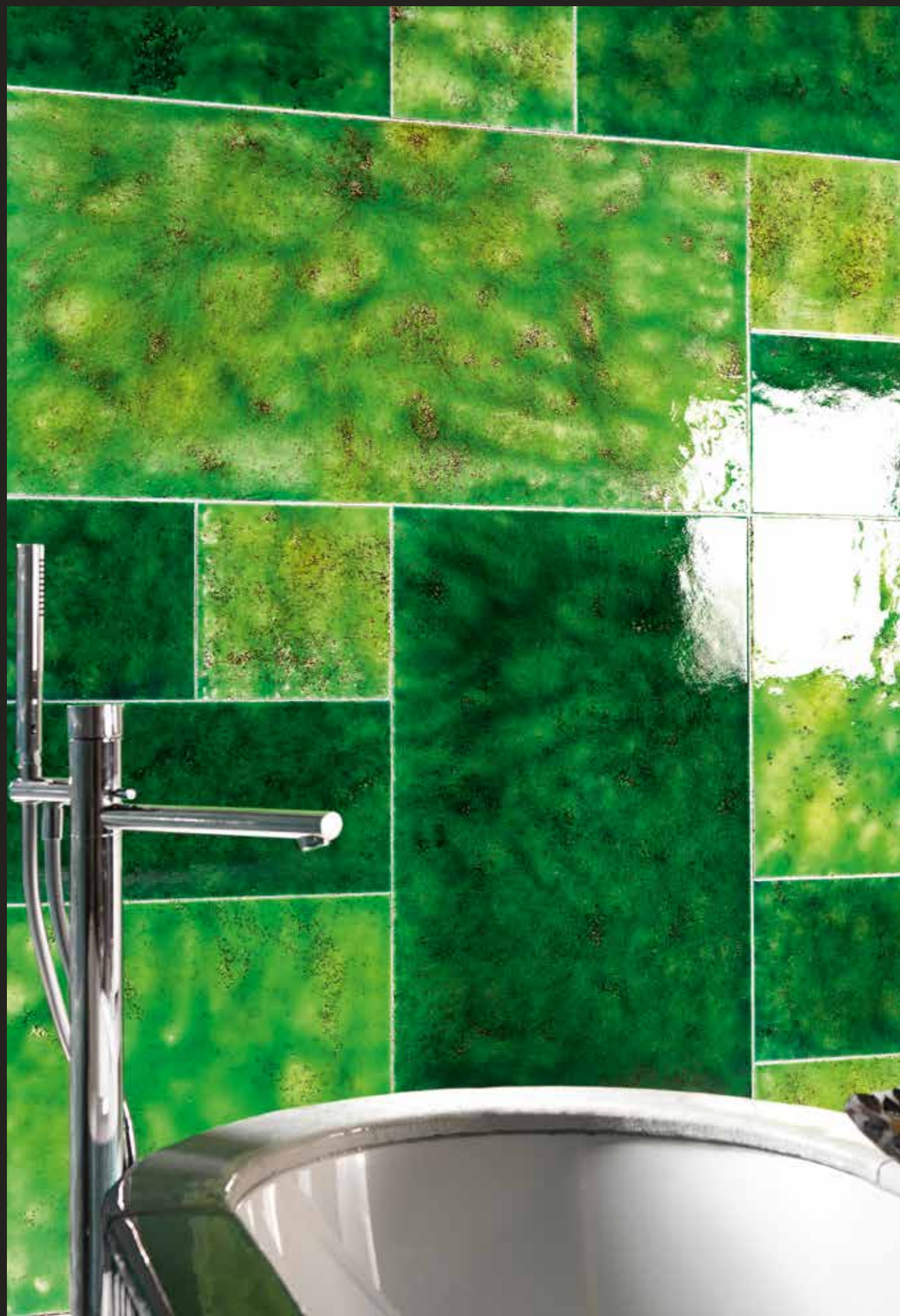

CANALETTO VERDE CHIARO

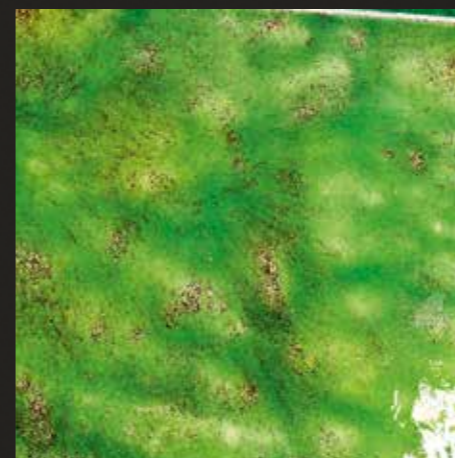

Il più raffinato ossido di rame é il componente principale per ottenere un verde intenso, profondo ed estremamente brillante.

Используем ценный оксид раме как основной компонент для получения насыщенного зеленого цвета придающего неотразимы вид материалу.

CANALETTO VERDE SCURO

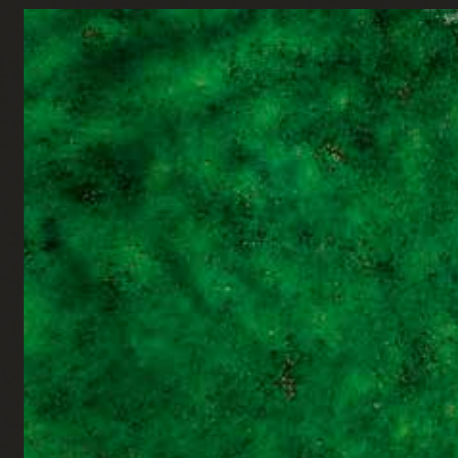

The most refined copper oxide is the principal component to obtain an intense green , deep and extremely brilliant.

L'oxyde de cuivre le plus raffiné est le composant principal pour obtenir une vert intense, profond et extrêmement brillant.



60x60 Canaletto Verde Chiaro/Verde Scuro LAVASTONE Pr.86 M²
60x120 Canaletto Verde Chiaro/Verde Scuro LAVASTONE Pr.86 Pcs
30x60 Canaletto Verde Chiaro/Verde Scuro LAVASTONE Pr.87 M²
30x30 Canaletto Verde Chiaro/Verde Scuro LAVASTONE Pr.83 M²

CANALETTO + BIANCO



Vetro di Murano in grani seminato manualmente a grosso spessore miscelando vetri bianchi e trasparenti in diverse granulometrie. Un effetto tridimensionale che non ha eguali nel mondo ceramico.

Murano glass in grains is manually seeded in great thickness by mixing white and transparent glasses, in different granulometries. A 3D (three-dimensional) effect that doesn't have compares in the ceramic world.

В этой серии используется Стекло Мурано в гранулах разного калибра белого и прозрачного цветов нанесенных в ручную. Получаемый эффект 3D не имеет аналогов в мире керамики.

Verre de Murano en grains est tête de série manuellement en grande épaisseur, en mélangeant des verres blancs et transparents dans différentes granulométries. Un effet 3D (en trois dimensions) qui n'a pas de comparaison dans le monde de la céramique.



WELLNESS & SPA

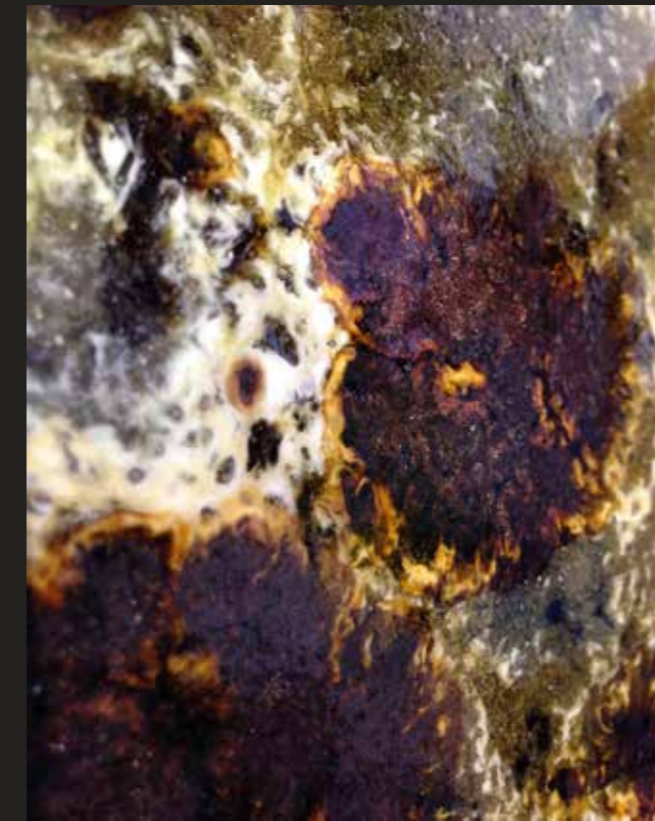
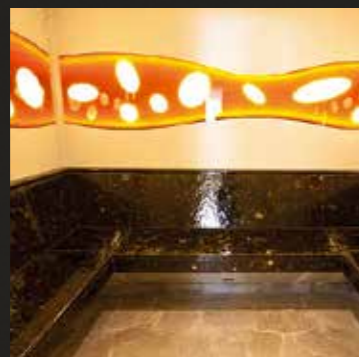
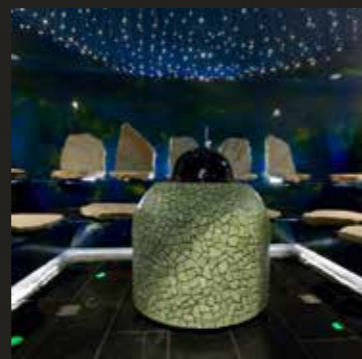

Thanks to the incredible resistance to the attack of chemical agents, besides the unbelievable value of heat exchange, the glazed lava stone is the best solution ever for interventions in SPA or Wellness areas.

Merci à l'incroyable résistance à l'attaque d'agents chimiques, en plus de la valeur invraisemblable de l'échange thermique, la pierre de lave émaillée est la meilleure solution jamais pour les interventions dans les zones Wellness ou SPA

Grazie all'incredibile resistenza all'attacco di agenti chimici, oltre all'incredibile valore di scambio termico, la pietra lavica smaltata é la migliore soluzione in assoluto per interventi in aree SPA e Wellness .

Благодаря натуральной прочности и способности выдерживать большие перепады температур с дополнительной защитой в виде эмали, каменная лава становится идеальным отделочным материалом для СПА салонов (бань, бассейнов, душевых, зон отдыха).

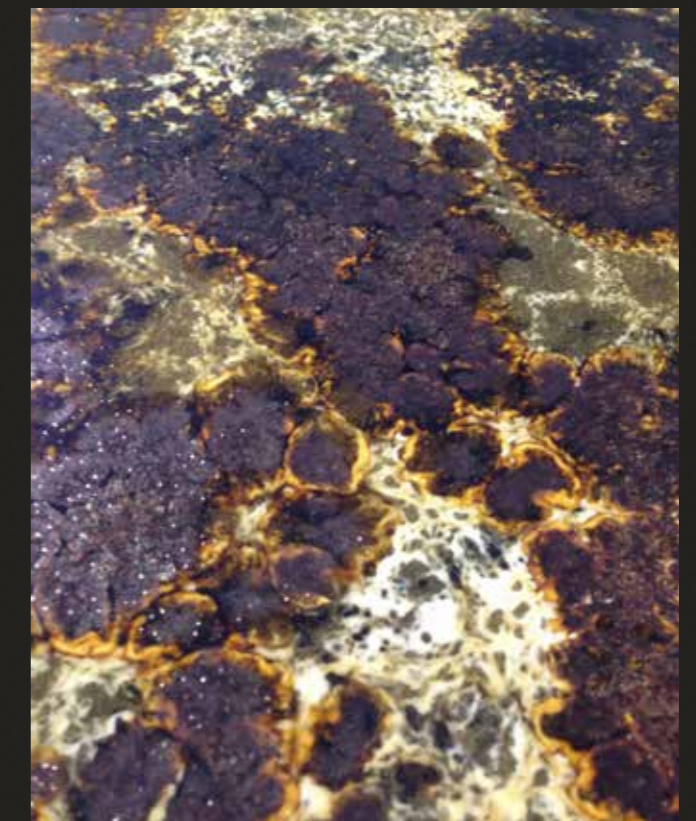

SOFFIO D'ESTATE VERDE



20x60 MP01 White Diamond S.Metalli Preziosi CERAMIC Pr.68 M²
20X60 decoro Soffio D'estate verde chiaro composizione su MP01 5Pz. CERAMIC Pr.84 Comp.
1,8X60 Canaletto Verde Chiaro LAVASTONE Pr.42 Pcs.
OPUS 3-6CM Canaletto Verde Chiaro LAVASTONE Pr.99 M²
60X60 DS344 Verde Acido DESERTO Lavico LAVASTONE Pr.86 M²



Una pennellata soffice e delicata per ottenere un decoro sviluppato su 5 pz 20x60 bianco MP01, coordinato a tutti i colori della serie Galassia e Canaletto.

A soft and delicate brushstroke to obtain a decoration developed on 5 pieces 20x60 white diamond MP01, coordinated to each colors of Galassia and Canaletto collections.

Очень красивый и уточненный стиль с использованием декора из 5 шт. 20x60 белого цвета мп01 в сочетании со всеми цветами серии галактика и каналетто.

Un coup de pinceau doux et délicat pour obtenir une décoration développée sur 5 pièces 20x60 White Diamond MP01, coordonné à chaque couleur des collections Galassia et Canaletto.



20x80 Doghe in pietra lavica Canaletto Verde Chiaro LAVASTONE Pr.98 M²



PERSONALIZZARE e CREARE

Con canaletto ogni tua idea, o quasi, può trasformarsi in un progetto realizzabile.

CUSTOMIZE and CREATE

With CANALETTO almost all your ideas can become a realizable project.

Создавай свое

С серией каналетто даже самая смелая идея превращается в реальный проект.

PERSONNALISER ET CREER

Avec CANALETTO presque toutes vos idées peuvent devenir un projet de réalisation.

SOFFIO D'ESTATE



60X60 DS344 Verde Acido con decoro Soffio D'estate su LAVASTONE
composizione 3 Pz. Pr.100 Comp.



SOFFIO d'ESTATE nero

20x60 COMPOSITION OF 5 Pcs. CERAMIC
Pr.84 composition



SOFFIO d'ESTATE blu

20x60 COMPOSITION OF 5 Pcs. CERAMIC
Pr.84 composition



SOFFIO d'ESTATE corallo

20x60 COMPOSITION OF 5 Pcs. CERAMIC
Pr.84 composition



SOFFIO d'ESTATE bordeaux

20x60 COMPOSITION OF 5 Pcs. CERAMIC
Pr.84 composition



SOFFIO d'ESTATE azzurro

20x60 COMPOSITION OF 5 Pcs. CERAMIC
Pr.84 composition

CANALETTO+ AMETISTA MURANO+

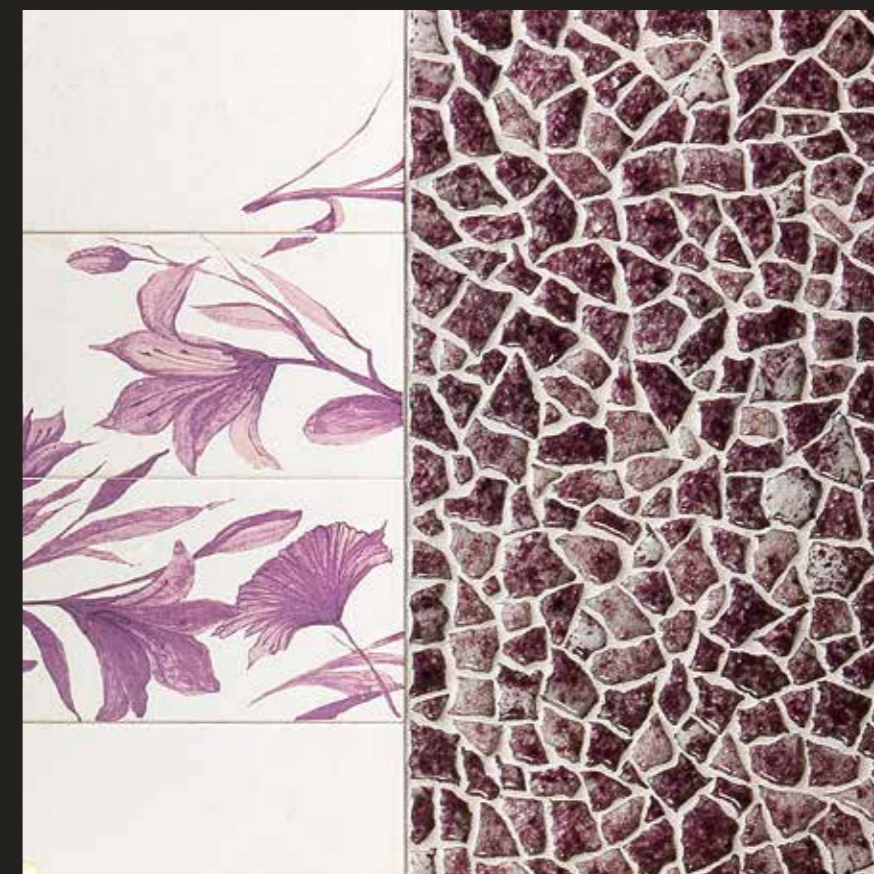

Opus 3-6 cm Canaletto+ Ametista Murano+ LAVASTONE Pr.100 M²
Macro Opus Canaletto+ Ametista Murano+ LAVASTONE Pr.92 M²
60x60 Canaletto+ Bianco Murano+ LAVASTONE Pr.92 M²

20x60 MP01 White Diamond Metalli Preziosi CERAMIC Pr.68 M²

20x60 Decoro Soffio D'estate ametista composizione su MP01 5pz. CERAMIC Pr.84 Comp.

20x60 Radici Canaletto+ Ametista Murano+ LAVASTONE Pr.73 Pcs.

CANALETTO + AMETISTA MURANO+



20x60 MP01 White Diamond Metalli Preziosi CERAMIC Pr.68 M²
20x60 Decoro Soffio D'estate Ametista composizione 5pz. CERAMIC Pr.84 Comp.
20x60 Radici Canaletto+ Ametista Murano+ LAVASTONE Pr.73 Pcs.

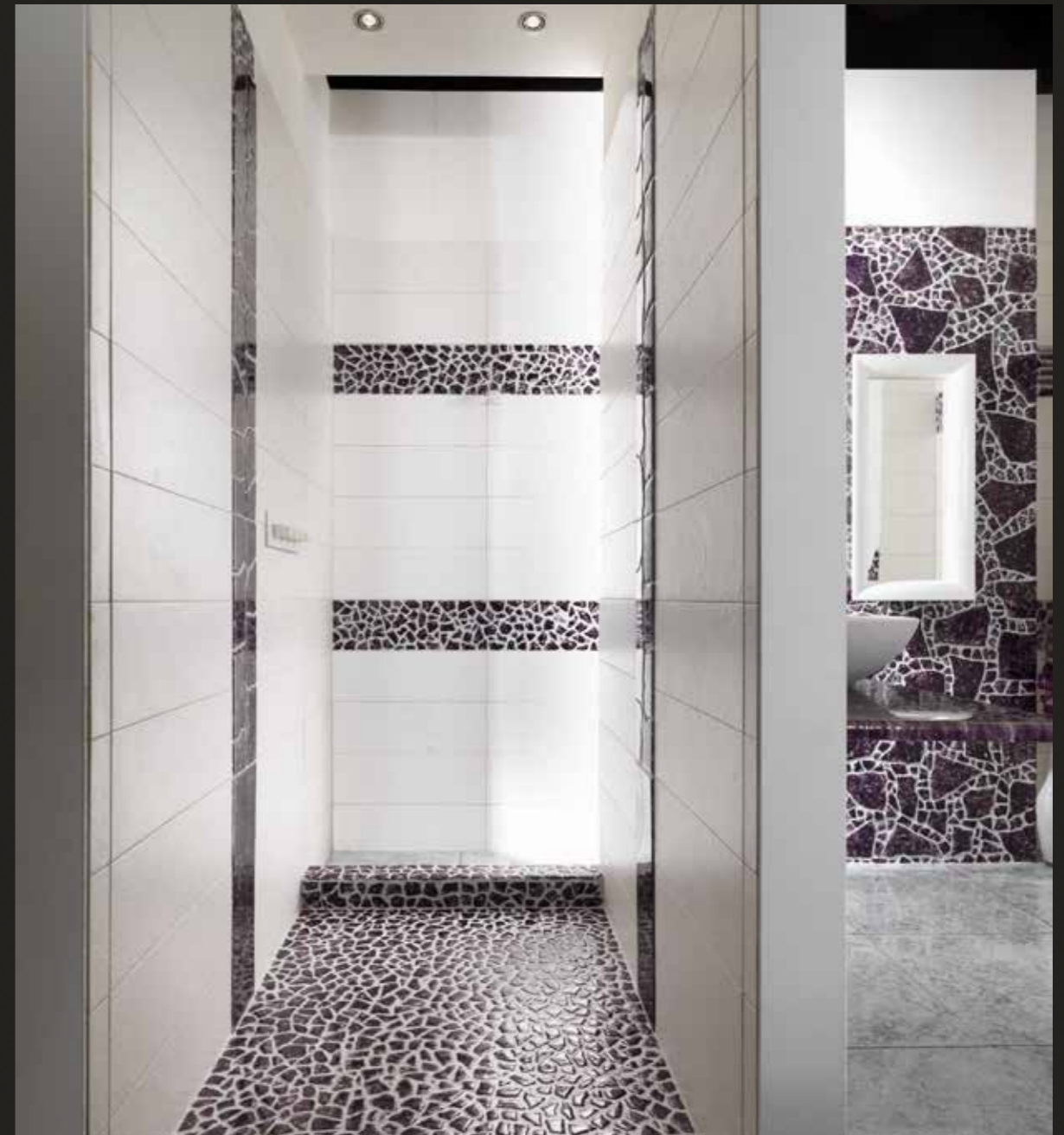

Opus 3-6 cm Canaletto+ Ametista Murano+ LAVASTONE Pr.100 M²
Macro Opus Canaletto+ Ametista Murano+ LAVASTONE Pr.92 M²
60x60 Canaletto+ Bianco Murano+ LAVASTONE Pr.92 M²

CANALETTO + AMETISTA MURANO+ DECORO SOFFIO D'ESTATE



20x60 MP01 White Diamond Metalli Preziosi CERAMIC Pr.68 M²

20x60 Decoro Soffio D'estate Ametista su MP01 5pz. CERAMIC Pr.84 Comp.

30x30 MP01 White Diamond Metalli Preziosi CERAMIC Pr.66 M²

Opus 3-6 cm Canaletto+ Ametista Murano+ LAVASTONE Pr.100 M²

CANALETTO + AMETISTA MURANO+ DECORO SOFFIO D'ESTATE



20x60 MP01 White Diamond Metalli Preziosi CERAMIC Pr. 68 M²
20x60 Decoro Soffio D'Estate Ametista su MP01
(compos. 5 pz.) CERAMIC Pr.84 pcs. Comp.
60x60 sp.1 lava Canaletto+ Ametista Murano+ LAVASTONE Pr.92 M²

Arredi d'Arte:

"Eldorado" scultura in Vetro e Ferro di Angelo Rinaldi





GALASSIA

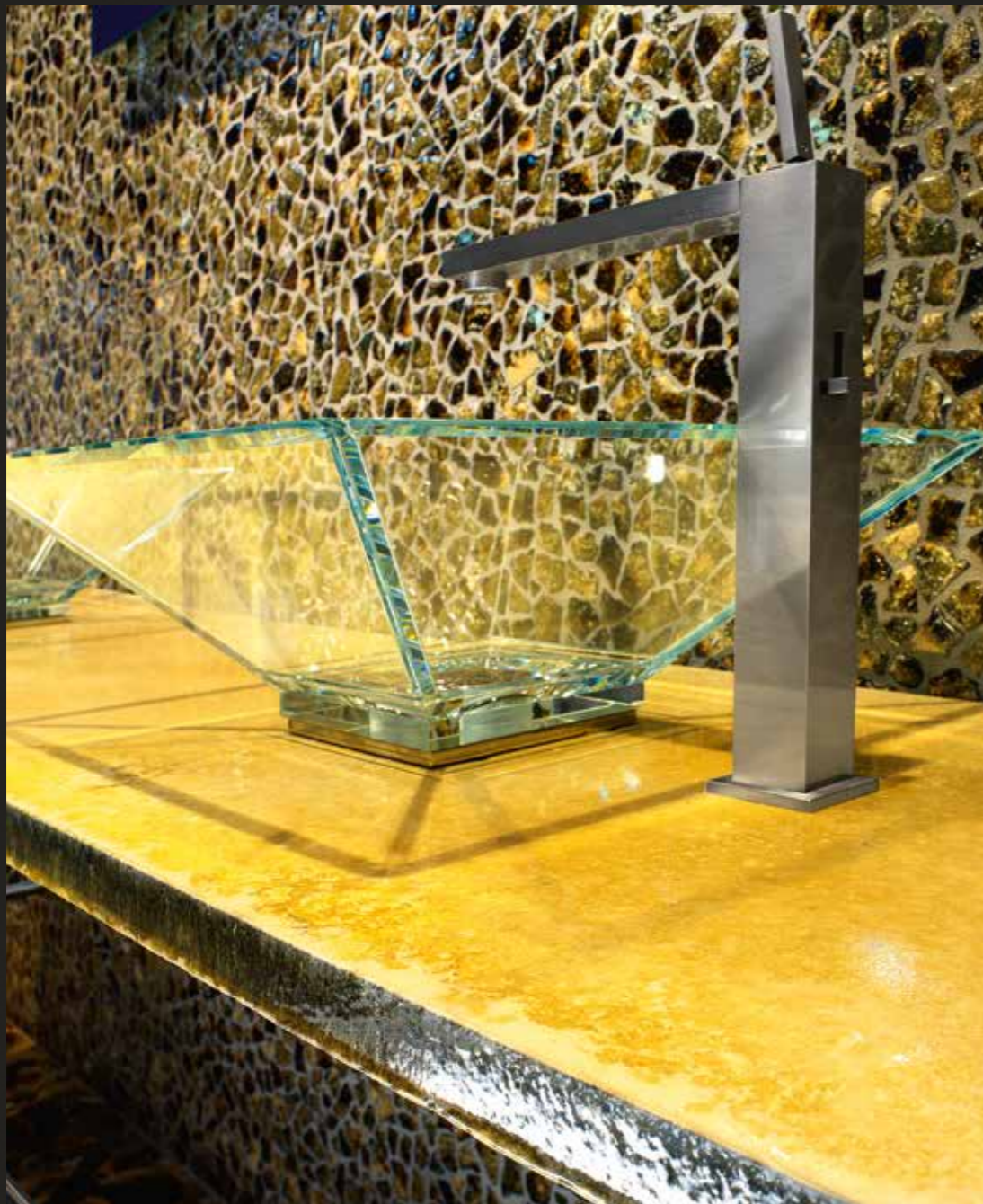

Ottenuto per gocciolatura di ossidi e smalti su pietra lavica si presenta con superfici disuniformi, miscelate nei colori dalla struttura ricca e corposa.

Obtained through the dripping of oxides and glazes on Lava stone shows uneven surfaces, mixed in the colors from the rich and full-bodied texture.

Эффект достигающийся капельным нанесением оксидов и эмали на каменную лаву результатом является неповторимая, насыщенная композиция цветов и узоров.

Obtenu par l'égouttement d'oxydes et émaux sur pierre de lave montre des surfaces irrégulières, mélangés dans les couleurs de la texture riche et corsé.

Top in pietra lavica Mania Twin 50x180 colore Canaletto Miele LAVASTONE Pr.117 Pcs
Opus 3-6 cm galassia miele LAVASTONE Pr.99 M²



Architetto Elena Gogoleva. Studio TreVi - Russia, Samara



Opus 3-6 cm galassia miele LAVASTONE Pr.99 M²



60x60 Radici Galassia Miele LAVASTONE Pr.82 Pcs
 30x30 Radici Galassia Miele LAVASTONE Pr.68 Pcs
 30x60 Radici Galassia Miele LAVASTONE Pr.79 Pcs
 Opus 3-6 cm galassia Miele LAVASTONE Pr.99 M²

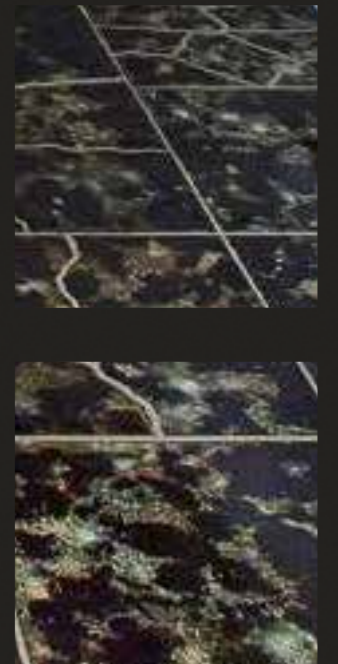

1,8x60 Galassia Giallo LAVASTONE Pr.42 Pcs
 1,8x60 Galassia Miele LAVASTONE Pr.42 Pcs
 10x30 DS360 Beige S. Deserto CERAMIC Pr.61 M²



GALASSIA BORDEAUX



Opus 3-6 cm Galassia Bordeaux LAVASTONE Pr.99 M²
20x60 MP02 Gold White Metalli Preziosi CERAMIC Pr.68 M²
20x60 MP26 Gold Purple Metalli Preziosi CERAMIC Pr.68 M²
5x60 (inciso su 20x60) MP26 Gold Purple Metalli Preziosi CERAMIC Pr.70 M²

GALASSIA GIALLO

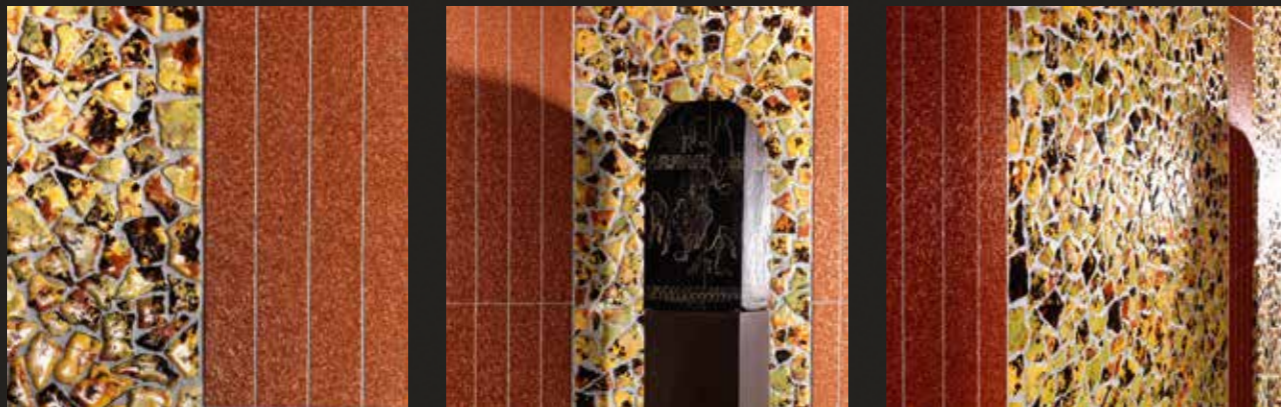

5x60 (inciso su 20x60) MP35 Gold OrangeMetalli Preziosi CERAMIC Pr.70 M2
OPUS 3-6 cm Galassia Giallo LAVASTONE Pr.99 M2
60x60 sp.1 lava Galassia Giallo LAVASTONE Pr.86 M2



GALASSIA GIALLO & BORDEAUX

Una miscela di smalti e pietra per realizzare colori caldi e accessi che trasmettano sensazioni di calore.

A mix of glazes and rock to realize surfaces from strong and bright colors that transmit feelings of warmth.

Это смесь эмали с каменной лавой для создания теплых цветов передающих ощущения летнего тепла.

Un mélange de émaux et de roches pour réaliser des surfaces avec couleurs fortes et vives qui transmettent des sensations de chaleur.



Opus 3-6 cm Galassia Giallo LAVASTONE Pr.99 M²



GALASSIA GIALLO & BORDEAUX



10x30 DS300 Bianco S.Deserto CERAMIC Pr.61 M²

Macro Opus 10-20 cm Galassia Giallo - Bordeaux LAVASTONE Pr.90 M²

2,3x9,8 mosaico su rete 30x30 Galassia Giallo LAVASTONE Pr.63 x sheet

2,3x9,8 mosaico su rete 30x30 Galassia Bordeaux LAVASTONE Pr.63 x sheet



GALASSIA GIALLO MOSAICO

Tagliato e smaltato a mano pezzo per pezzo come gli antichi maestri mosaicisti sapevano fare, per donare un aspetto artistico e unico ad ogni pezzo.

Cut and glazed by hand piece by piece as the ancient mosaic masters knew to do, to give an artistic and unique aspect to every single piece.

Разрезаны и покрыты эмалью штука за штукой как это делали мастера прошлых веков для придания уникального вида каждому элементу.

Couper et émailler à la main pièce par pièce comme les anciens maîtres mosaïstes savaient faire, pour donner un aspect artistique et unique à chaque pièce.



2,3x4,8 mosaico su rete 30x30
Galassia Giallo LAVASTONE Pr.66 x sheet

GALASSIA GIALLO



Opus 3-6 cm Galassia Giallo LAVASTONE Pr.99 M²
10x30 DS332 Giallo S.Deserto CERAMIC Pr.61 M²
20x20 DS334 Mimosa S.Deserto CERAMIC Pr.61 M²

GALASSIA VERDE OPUS



Opus 3-6 cm Galassia Verde LAVASTONE Pr.99 M²
20x60 MP02 Gold White Metalli Preziosi CERAMIC Pr.68 M²
5x60 (inciso su 20x60) MP52 Dark Green metalli Preziosi CERAMIC Pr.70 M²

GALASSIA NERO



Lastre 20x80 Galassia Nero LAVASTONE Pr.98 M²



opus 3-6 cm Galassia Nero LAVASTONE Pr.99 M²



Sink Design - in collaboration with Valdama



Lavabo SEED 45x40 h15cm CANALETTO CERAMIC BLU Pr. Pr. 97 Pcs.
Sink SEED 45x40 h15cm CANALETTO CERAMIC BLU Pr. Pr. 97 Pcs.



Piletta in ABS cromato con tappo in ceramica smaltata Pr. 67 Pcs.
Chrome ABS free flow with glazed ceramic drain Pr. 67 Pcs.

Sink Design - in collaboration with Valdama



Lavabo POD 42x42 h15cm CANALETTO CERAMIC VERDE CHIARO Pr. 90 Pcs.
Sink POD 42x42 h15 CANALETTO CERAMIC VERDE CHIARO Pr. 90 Pcs.



Piletta in ABS cromato con tappo in ceramica smaltata Pr. 67 Pcs.
Chrome ABS free flow with glazed ceramic drain Pr. 67 Pcs.



ORO VENEZIA



Vero oro 24kt applicato su pregiati smalti e pietra lavica, per ottenere rivestimenti e soluzioni d'arredo uniche ed inimitabili. Realizzato in 3° fuoco, la collezione ORO VENEZIA si presenta nelle finiture oro e platino.

Настоящее золото в 24 каратана наносится на ценную эмаль и каменную лаву предавая неповторимый шик и высокий стиль вашему проекту. Проходя три этапа обжига в печи, коллекция Венецианское золото доступно в обработке: золото или платина.

Real Gold 24Kts applied on fine glazes and lava stone to obtain coverings and decorating solutions, unique and incomparable!

Realized with 3rd firing process, the collection ORO VENEZIA can be produced in Gold or Platinum version.

Vrai Or 24Kts appliqué sur fins émaux et pierre de lave pour obtenir des revêtements et des solutions de décoration, uniques et incomparables! Réalisé en 3ème feu, la collection ORO VENEZIA peut être produite dans la version Gold ou Platinum.

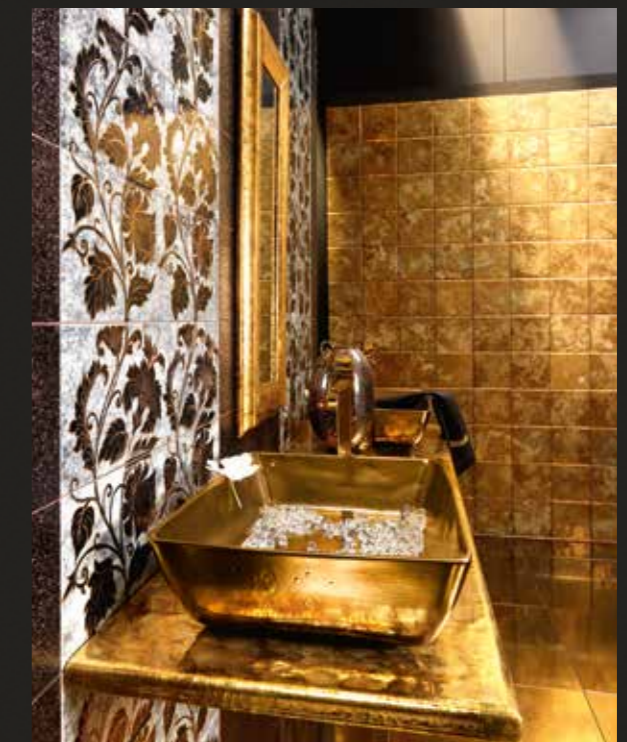

20x60 MP55 Gold Black Metalli Preziosi CERAMIC Pr.68 M²
20x60 Decoro Canalgrande-1 e -2 Nero filo oro CERAMIC Pr.72 Pcs



2,3x4,8 Oro Venezia
mosaico su rete 30x30
San Marco Oro su Galassia Miele
LAVASTONE Pr.76 x sheet

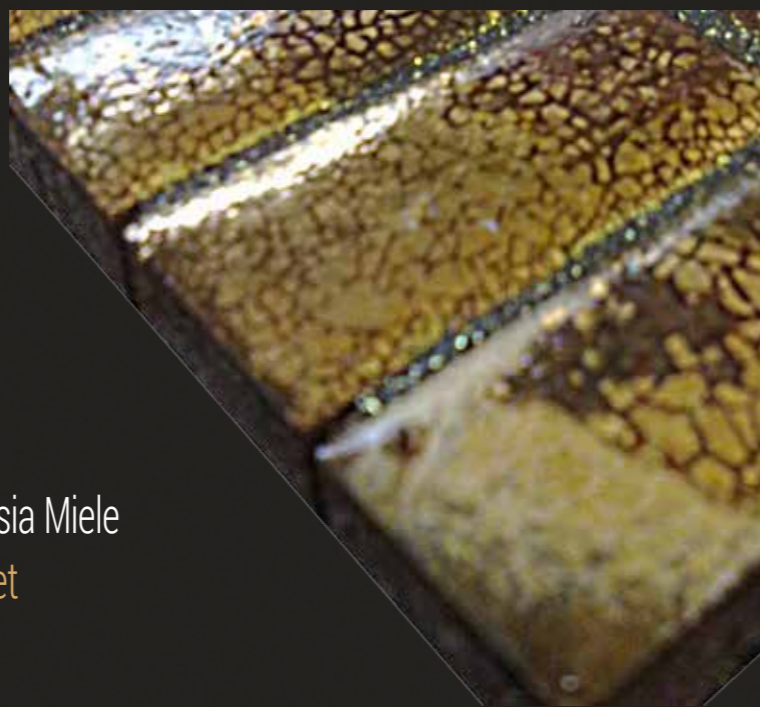

5x60 (inciso su 20x60) MP55 Gold Black
Metalli Preziosi CERAMIC Pr.70 M²

2,3x4,8 Oro Venezia mosaico su rete 30x30
Galassia Miele LAVASTONE Pr.76 x sheet

OPUS 3-6 cm Oro Venezia
San Marco Oro su Galassia Miele LAVASTONE Pr .104 M²

ORO VENEZIA San Marco su OPUS CANALETTO blu

L'applicazione dell'oro a 3° fuoco, sulla finitura Canaletto, crea un effetto craquelé colorato in oro e blu.

Un effetto speciale che solo l'utilizzo di questi materiali consente di ottenere.

The application of Gold in 3rd firing process on Canaletto finishing, creates a crackle effect colored in gold and blue. A special effect that only the use of these precious materials allows to obtain.

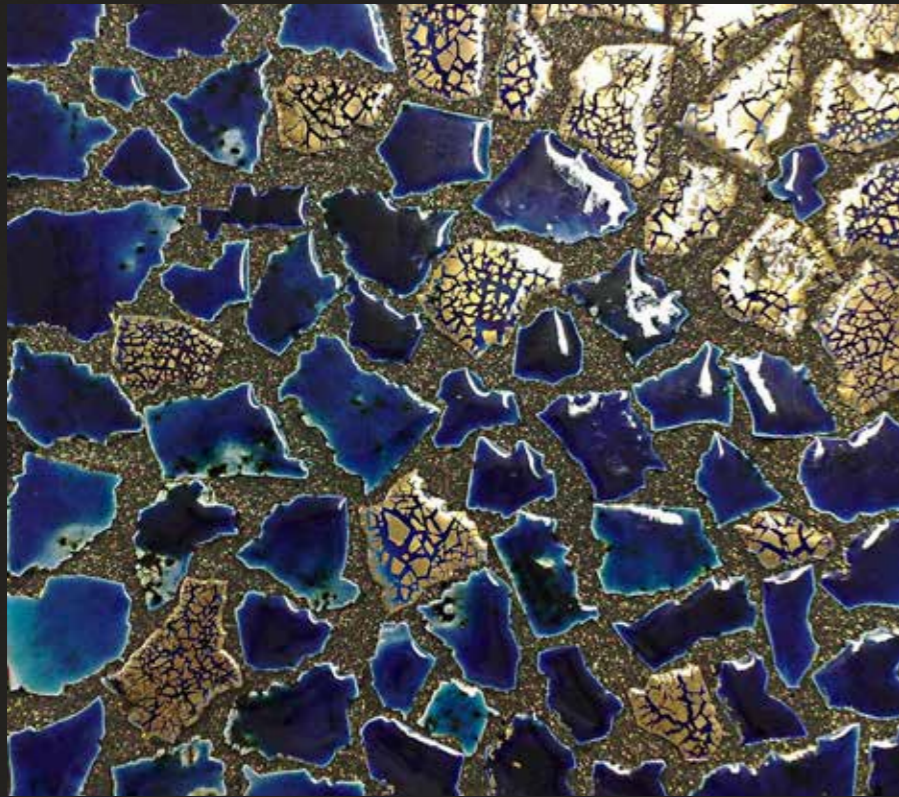

Opus 3-6 cm Oro Venezia San Marco ORO
mix canaletto blu LAVASTONE

ORO VENEZIA San Marco su OPUS CANALETTO azzurro

Нанесение золота перед 3м обжигом дает эффект со старенного материала с крапинами синего цвета.

Это специальный эффект добиться которого возможно только с помощью этих материалов.

L'application de l'Or en 3ème feu sur la finition Canaletto, crée un effet craquelé de couleur Or et Bleu.

Un effet particulier que seulement l'utilisation de ces précieux matériaux permet d'obtenir.



Opus 3-6 cm Oro Venezia San Marco
mix Canaletto Azzurro LAVASTONE

ORO VENEZIA San Marco su GALASSIA GIALLO



Opus 3-6 cm Oro Venezia San Marco
mix Galassia Giallo LAVASTONE

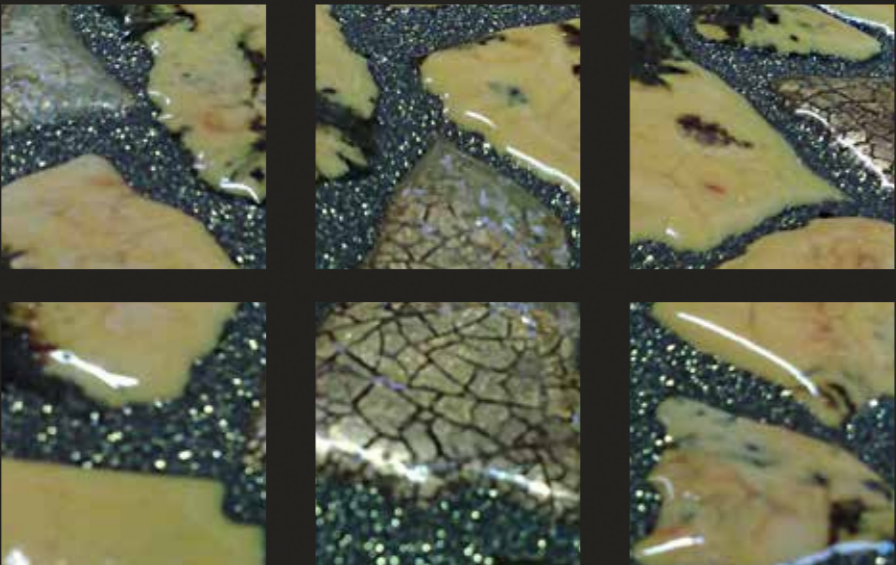

ORO VENEZIA San Marco su GALASSIA BORDEAUX

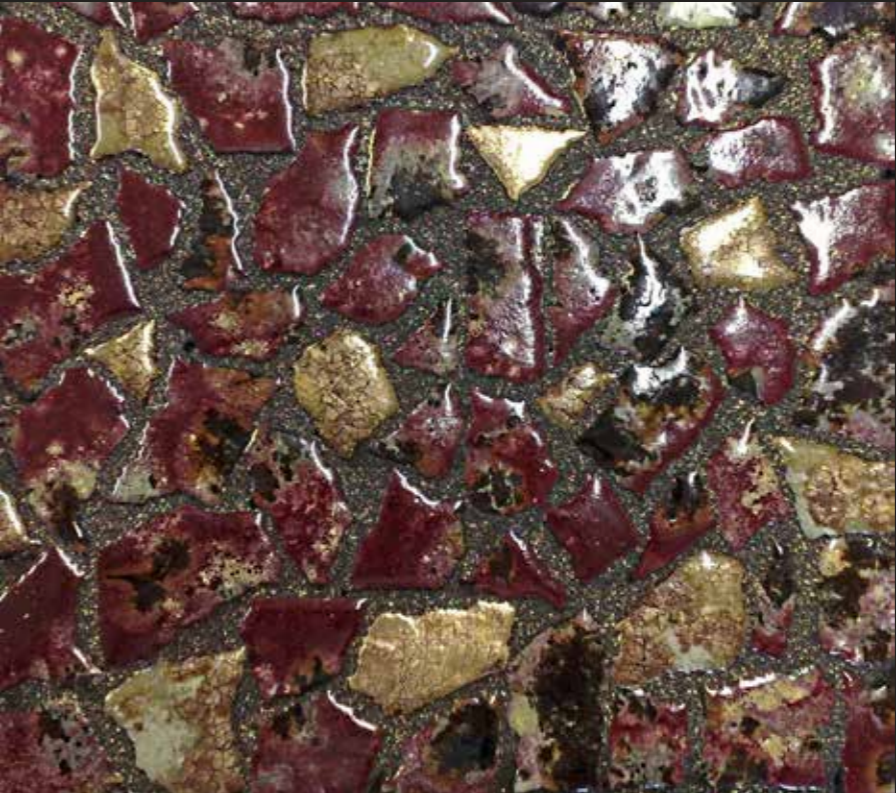

Opus 3-6 cm Oro Venezia San Marco
mix Galassia Giallo LAVASTONE

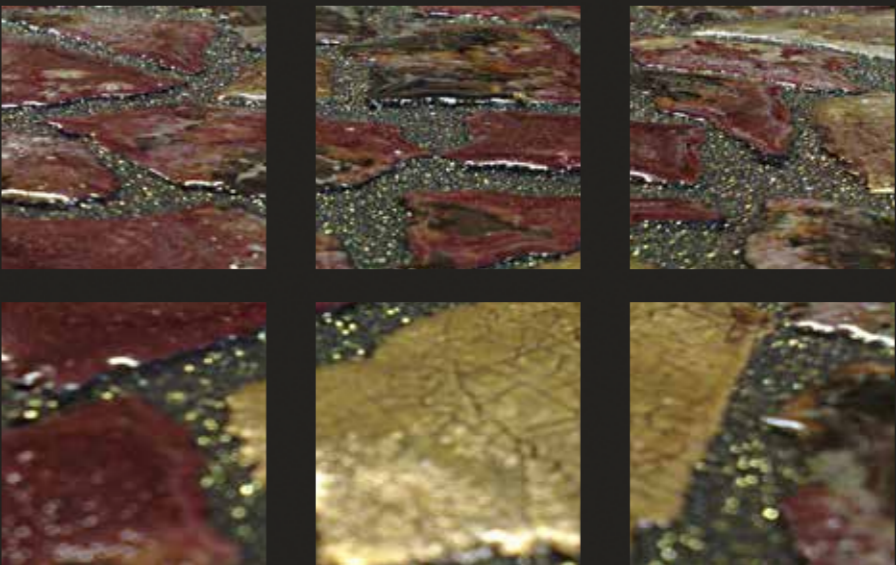

DECORO DAMASCO



60x60 lava Damasco cristallizzato LAVASTONE Pr.76 Pcs

DECORO DAMASCO

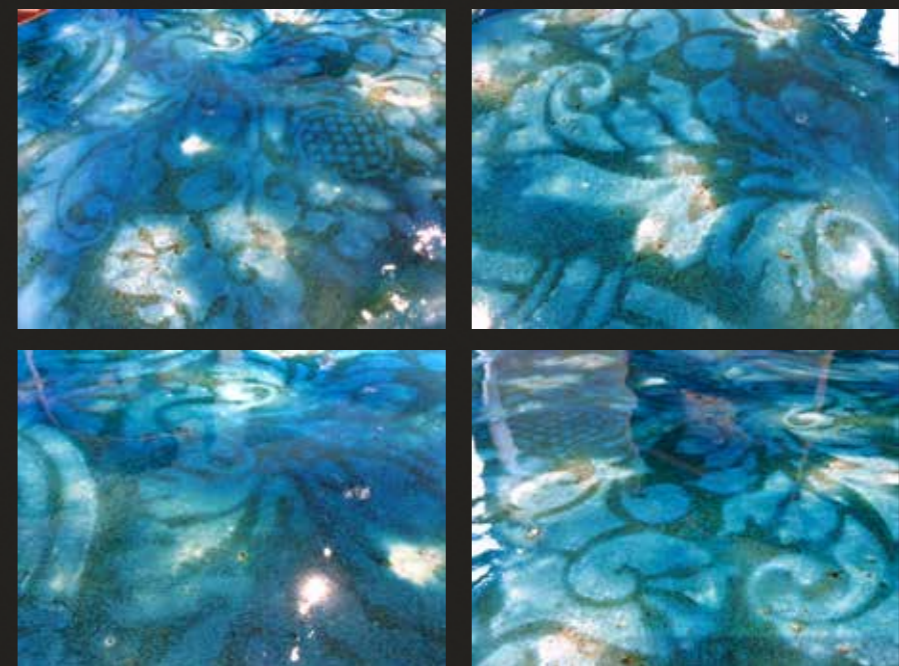
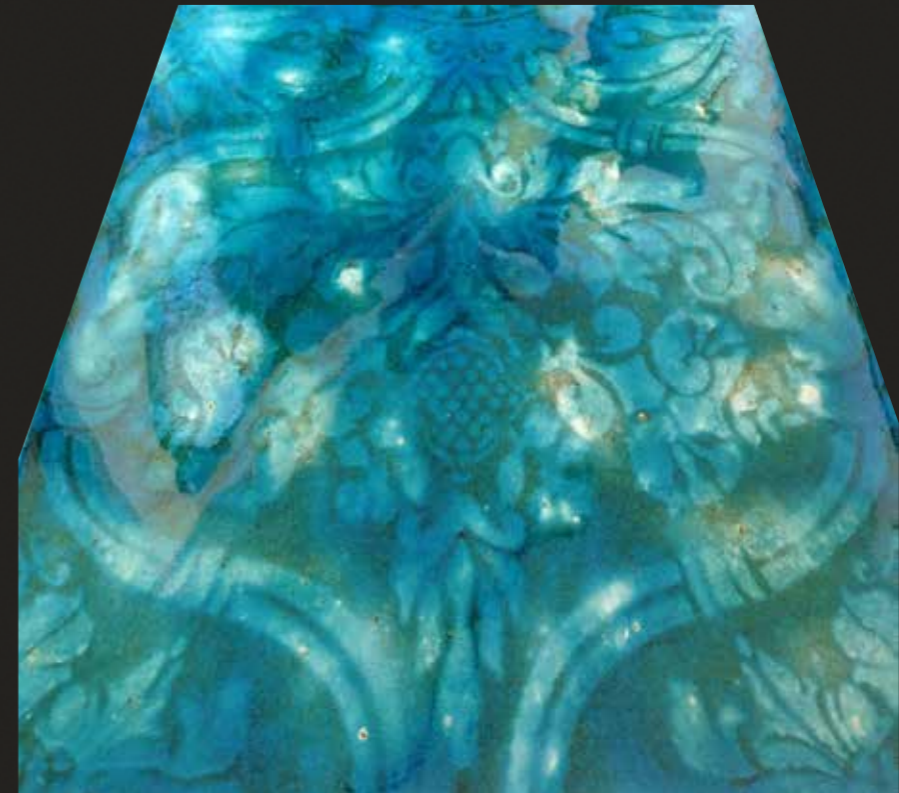

60x60 lava Damasco canaletto azzurro LAVASTONE Pr.78 Pcs

PIATTI DOCCIA SU MISURA max 100x200 spess. 2-3 cm

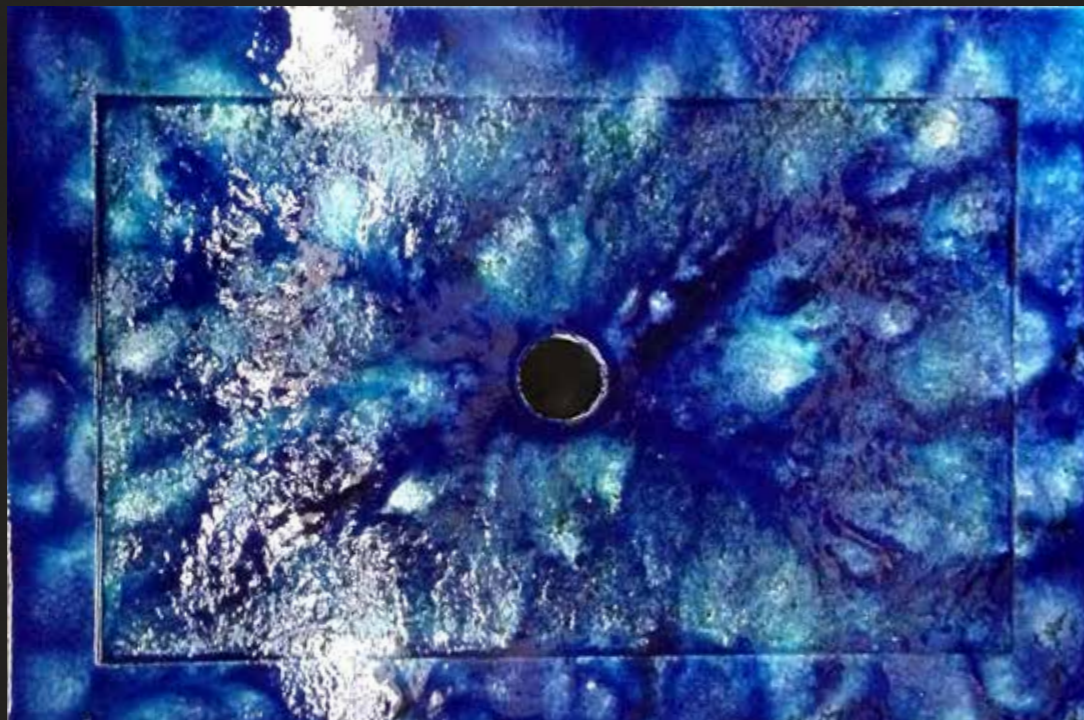

Di spessore 3 o 5 cm, i piatti doccia in pietra lavica smaltata possono essere realizzati nelle collezioni Canaletto e Galassia su ordinazione e preventivo, con dimensione massima a pezzo unico di 90x180 cm.

Shower plates in glazed lava stone, of 3 or 5 cm thickness, can be realized in the collections CANALETTO and GALASSIA under commission, and quotation for maximum dimensions in an only piece of 90x180 cm.

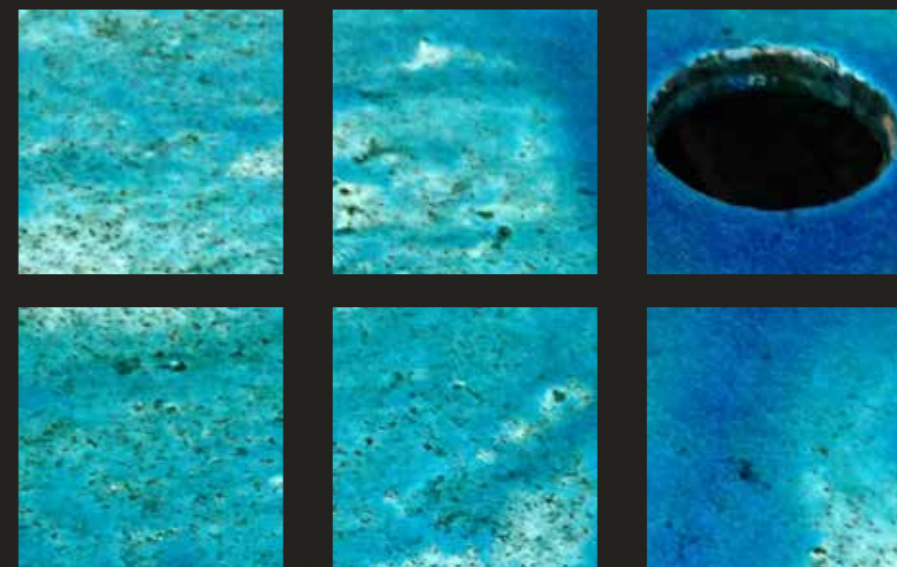

Поддоны для душевых толщиной в 3 или 5 см. из каменной лавы покрытие эмалью могут быть изготовлены по вашим размерам (максимальный размер одного поддона 90x180 см.) в кол лекциях каналетто и галактика.

Plaques de douche émaillée en pierre de lave, de 3 ou 5 cm d'épaisseur, peuvent être réalisés dans les collections CANALETTO et GALASSIA sous commission, et devis, pour les dimensions maximales dans une seule pièce de 90x180 cm

TOP e PIATTI DOCCIA
TOPS and SHOWER PLATES
Столешницы
TOPS et PLAQUES de Douche

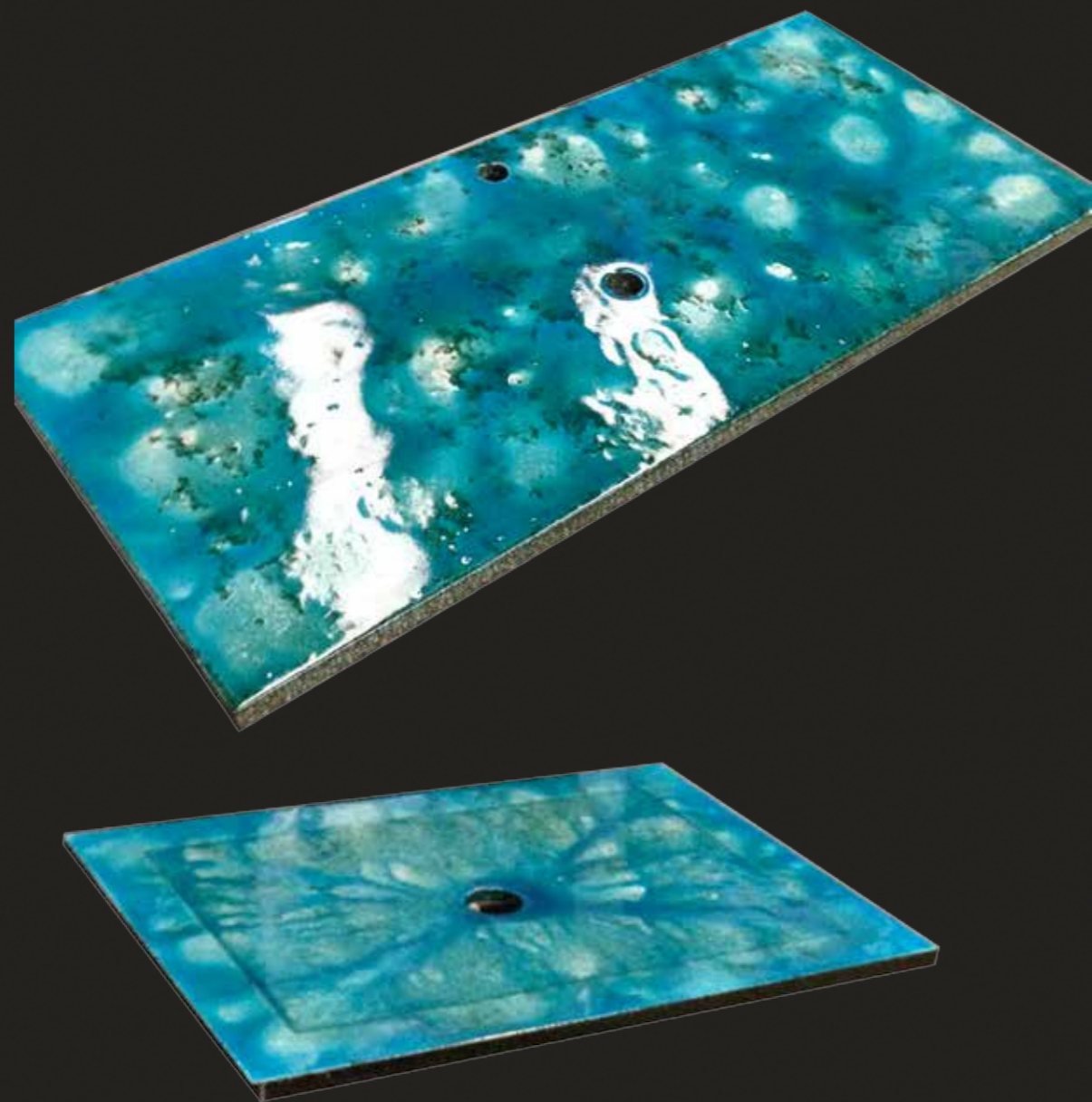

Di spessore 2 / 3 / 4 o 5 cm, i Piatti doccia ed i Top in pietra lavica smaltata, possono essere realizzati nelle collezioni Canaletto e Galassia su ordinazione e preventivo con dimensione massima a pezzo unico di 90x180 cm.

Tops and Shower plates in glazed lava stone, of 2 / 3 / 4 or 5 cm thickness, can be realized in the collections CANALETTO and GALASSIA under commission, and quotation for maximum dimensions in an only piece of 90x180 cm.

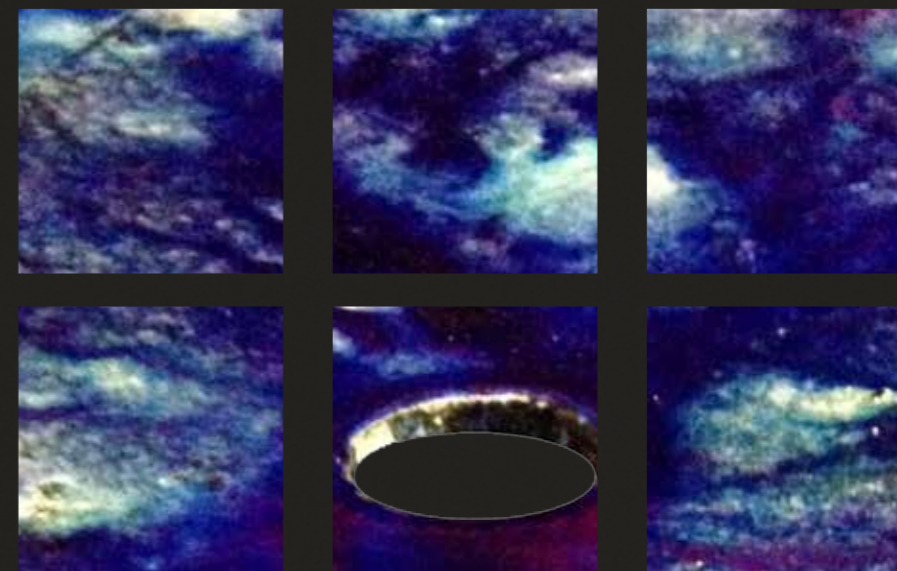

Столешницы толщиной в 2 / 3 / 4 / 5 см. из каменной лавы покрытой эмалью могут быть изготовлены по вашим индивидуальным размерам в коллекциях каналетто и галактика с максимальным размером одной панели 90x180 см.

Tops et plaques de douche émaillée en pierre de lave, de 2/3/4 ou 5 cm d'épaisseur, peuvent être réalisés dans les collections CANALETTO et GALASSIA sous commission, et devis, pour les dimensions maximales dans une seule pièce de 90x180 cm.

CANALETTO

Pietra lavica smaltata con speciali cristalline e vetri di Murano.

Glazed Lava Stone with special Crystallines and Murano glasses.

Каменная лава покрытая эмалью и крошкой кристаллов из стекла Мурано.

Pierre de lave émaillée avec cristallines particulières et verres de Murano.

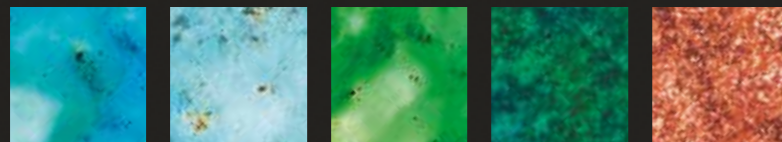

Azzurro Cielo Verde chiaro Verde scuro Rosso

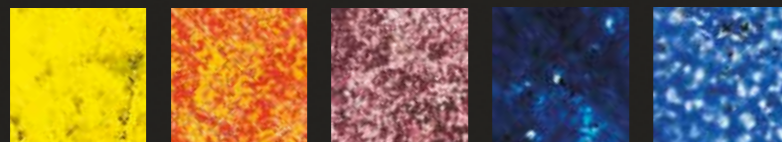

Giallo Rosso giallo Rosa Blu Bluette



GALASSIA

Pietra lavica smaltata con ossidi e smalti.

Glazed Lava Stone with glazes and oxides.

Каменная лава покрытая окислами и эмалью.

Pierre de lave émaillée avec des émaux et des oxydes.



Verde Miele Turchese

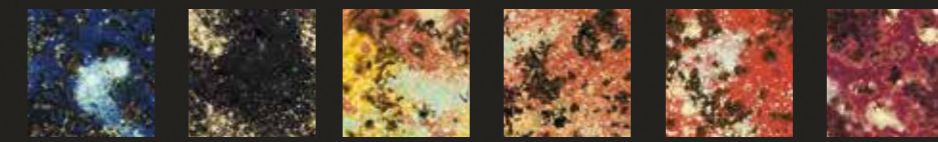











Blu Nero Giallo Cuoio Corallo Bordeaux

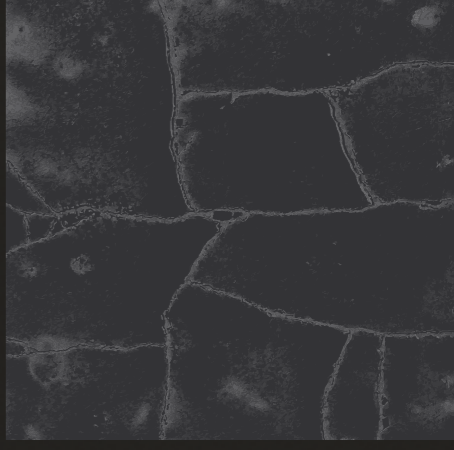

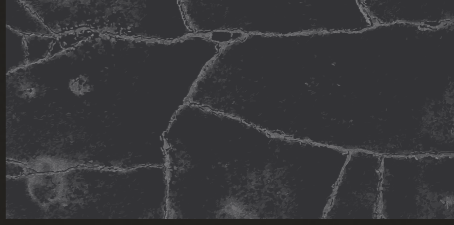
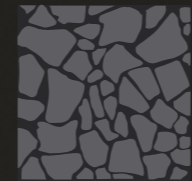
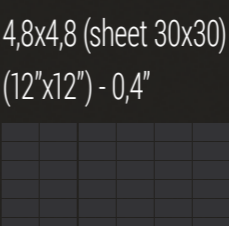
GALASSIA e CANALETTO formati

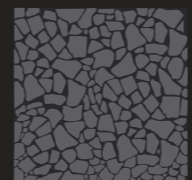
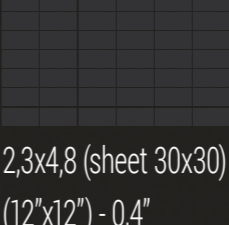
	Pr.42 pcs Pr. 37 x 100 pcs		Pr.96 M²
	Pr.44 pcs		10x10 sp.1cm (4"x4") - 0,4"
	Pr.91 M²		Pr.95 M²
	Pr.88 M²		15x15 sp.1cm (6"x6") - 0,4"
	Pr.87 M²		Pr.86 M²
	Pr.86 Pcs		Pr.94 M²
	Pr.88 M²		Pr.83M²
	Pr.91 M²		

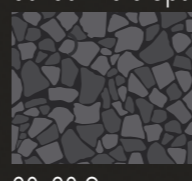
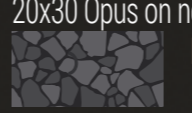
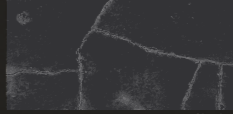
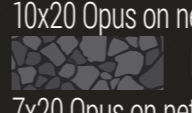
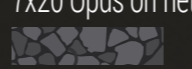
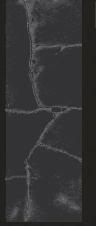
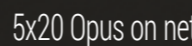
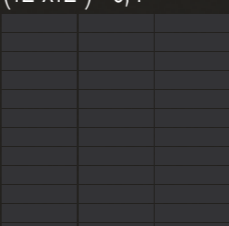
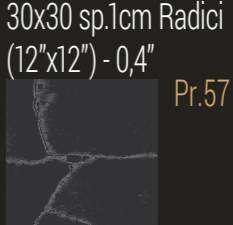
GALASSIA e CANALETTO opus - Mosaici e formati decorativi

	Opus -sp. 0,7cm		Mosaici 30x30 Mosaic (12"x12")		Radici sp.1 cm - Radici thick. 0,4"
	Pr.99 M² loose pieces		Pr.67 pcs		Pr.82 pcs
	Pr.90 M² loose pieces		Pr.63 pcs		Pr.79 pcs
	Pr.102 M²		Pr.66 pcs		Pr.71 pcs
	Pr.113 M²		Pr.60 Pcs		Pr.68 pcs
	Pr.43Pcs /Pr.69 MI		Pr.39 Pcs /Pr.66 MI		Pr.52 pcs
	Pr.35 Pcs /Pr.69 MI		Pr.63 pcs		Pr.57 pcs
					Pr.42 pcs

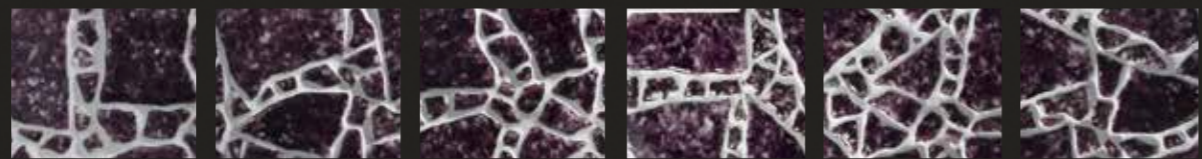

CANALETTO +

Pietra lavica smaltata con speciali vetri di Murano in varie granulometrie
 Glazed Lava Stone with special Murano glasses in different granulometries.

Каменная лава покрытая эмалью и крошкой кристаллов разного калибра из стекла Мурано.

Pierre de lave émaillée avec des verres de Murano spéciales, dans différentes granulométries.



Nerobianco Murano+ Nero Murano+ Marrone Murano+ Blu intenso Murano+ Turchese Murano+ Verde chiaro Murano+ Verde prato Murano+

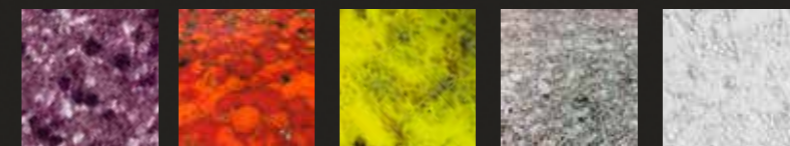













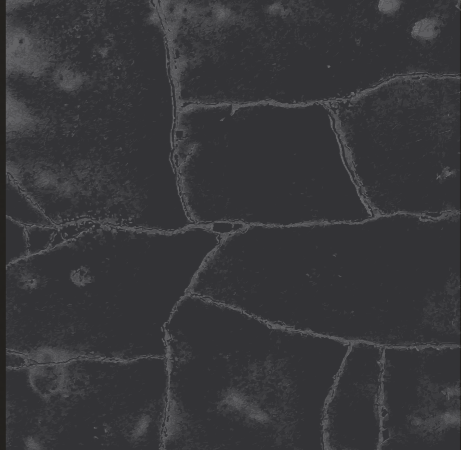

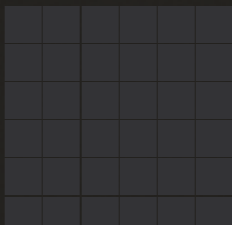

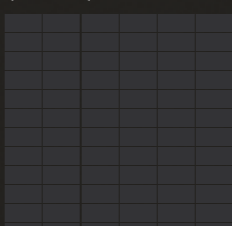
Ametista Murano+ Rossarancio Murano+ Giallo Murano+ Cristallo Murano+ Bianco Murano+

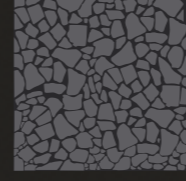
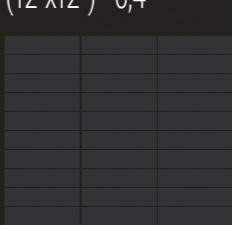

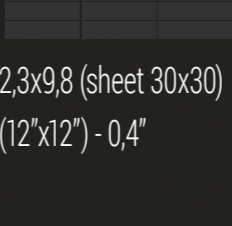
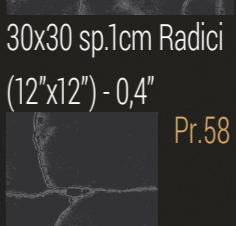
CANALETTO + formati

 Pr.46 pcs 1,8x60 sp.1cm (0,7"x24") - 0,4"	 Pr.97 M ² 10x10 sp.1cm (4"x4") - 0,4"
 Pr.49 pcs 5x60 sp.1cm (2"x24") - 0,4"	 Pr.96 M ² 15x15 sp.1cm (6"x6") - 0,4"
 Pr.95 M ² 10x60 sp.1cm (4"x24") - 0,4"	 Pr.92 M ² 60x60 sp.1cm (24"x24") - 0,4"
 Pr.93 M ² 20x60 sp.1cm (8"x24") - 0,4"	
 Pr.93 M ² 30x60 sp.1cm (12"x24") - 0,4"	 Pr.95 M ² 20x20 sp.1cm (8"x8") - 0,4"
 Pr.92 Pcs 60x120 sp.1cm (24"x48") - 0,4"	 Pr.86 M ² 30x30 sp.1cm (12"x12") - 0,4"
	 Pr.89 M ² 40x60x20 (16"x24"x8") - 0,4"

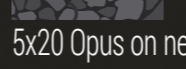
CANALETTO + opus - Mosaici e formati decorativi

 Pr.100 M ² Opus -sp. 0,7cm	 Pr.68 pcs Mosaici 30x30 Mosaic (12"x12")	 Pr.83 pcs Radici sp.1 cm - Radici thick. 0,4"
 Pr.92 M ² Opus incertum sfuso 3-6 cm	 Pr.64 pcs 2,3x2,3 (sheet 30x30) (12"x12") - 0,4"	 Pr.80 pcs 60x60 sp.1cm Radici (24"x24") - 0,4"
 Pr.103 M ² Macro Opus sfuso 10-20 cm loose pieces	 Pr.67 pcs 4,8x4,8 (sheet 30x30) (12"x12") - 0,4"	 Pr.73 pcs 30x60 sp.1cm Radici (12"x24") - 0,4"
 Pr.115 M ² 30x30 Opus sheet (12"x12") Opus 3-6 cm	 Pr.64 pcs 2,3x4,8 (sheet 30x30) (12"x12") - 0,4"	 Pr.69 pcs 20x60 sp.1cm Radici (12"x24") - 0,4"
 Pr.66 Pcs 30x30 Micro Opus (12"x12") 1-3 cm	 Pr.64 pcs 2,3x9,8 (sheet 30x30) (12"x12") - 0,4"	 Pr.58 pcs 30x30 sp.1cm Radici (12"x12") - 0,4"
 Pr.44 Pcs /Pr.70 MI 20x30 Opus on net	 Pr.53 pcs 10x30 sp.1cm Radici (4"x12") - 0,4"	
 Pr.40 Pcs /Pr.67 MI 10x20 Opus on net	 Pr.43 pcs 20x20 sp.1cm Radici (8"x8") - 0,4"	
 Pr.36 Pcs /Pr.70 MI 7x20 Opus on net	 Pr.43 pcs 10x10 sp.1cm Radici (4"x4") - 0,4"	
 Pr.36 Pcs /Pr.70 MI 5x20 Opus on net		

ORO VENEZIA

pietra lavica smaltata con vetri ossidi
smalti e finitura in ORO e PLATINO

COLORI ORO SAN MARCO



San Marco oro
su Galassia Giallo

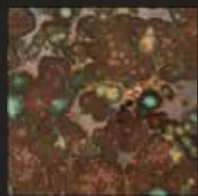

San Marco oro
su Galassia Verde



San Marco oro
su Canaletto Azzurro

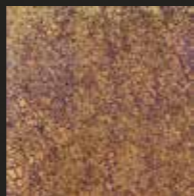

San Marco oro
su Canaletto Blu

COLORI PLATINO SAN MARCO



San Marco platino
su Galassia Miele

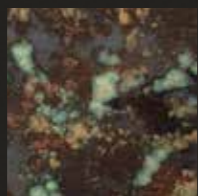

San Marco platino
su Galassia Verde





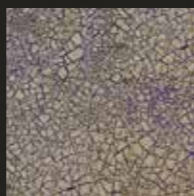





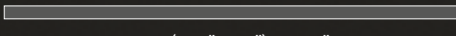

San Marco platino
su Canaletto Azzurro

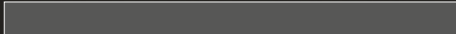

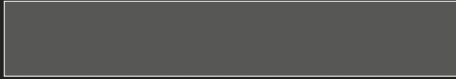

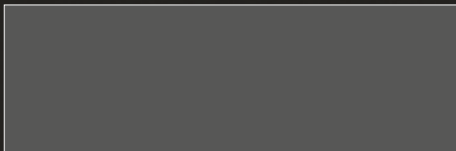
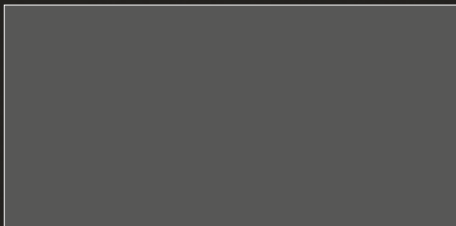

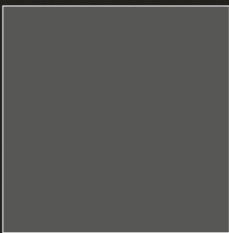
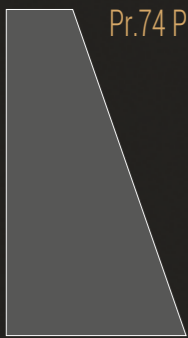





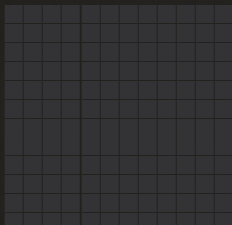
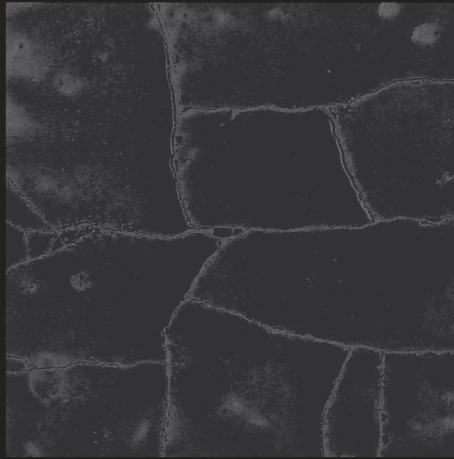

San Marco platino
su Canaletto Blu

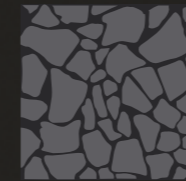
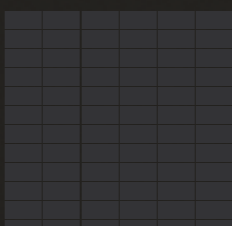

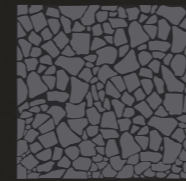
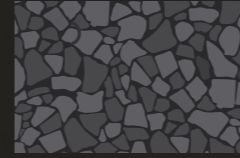
ORO VENEZIA formati

 Pr.66 pcs	 Pr.39 Pcs
 Pr.67 pcs	 Pr.53 Pcs
 Pr.69Pcs	 Pr.85 Pcs
 Pr.71 Pcs	
 Pr.74 Pcs	
 Pr.100 Pcs	 Pr.62 Pcs
	 Pr.67 Pcs
 Pr.74 Pcs.	
 Pr.69 Pcs.	

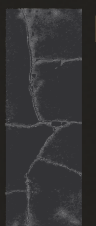
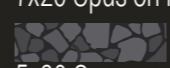
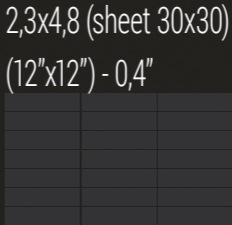
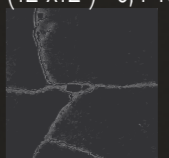
ORO VENEZIA opus - Mosaici e formati decorativi

Opus -sp. 0,7cm	Mosaici 30x30	Radici sp.1 cm - Radici thick. 0,4"
 Pr.112 M ² loose pieces	 Pr.77 pcs	 Pr.97 pcs
 Pr.101 M ² loose pieces	 Pr.74 pcs	 Pr.94 pcs
 Pr.75 x sheet	 Pr.76 pcs	 Pr.79 pcs
 Pr.137 x sheet	 Pr.70 Pcs	 Pr.72 pcs
 Pr.53 Pcs	 Pr.46 Pcs	 Pr.66 pcs
 Pr.41 Pcs	 Pr.74 pcs	 Pr.70 pcs
		 Pr.53 pcs

Galassia - Canaletto - Canaletto⁺ Top in pietra lavica

Top su misura a preventivo

Top of tailored quote

Топ заказ цитата

Top devis sur mesure

Spessori

толщина

Thick

épaisseur

Dimensioni

размер

size

taille

2 cm

MAX 100x200 cm

3 cm

4 cm

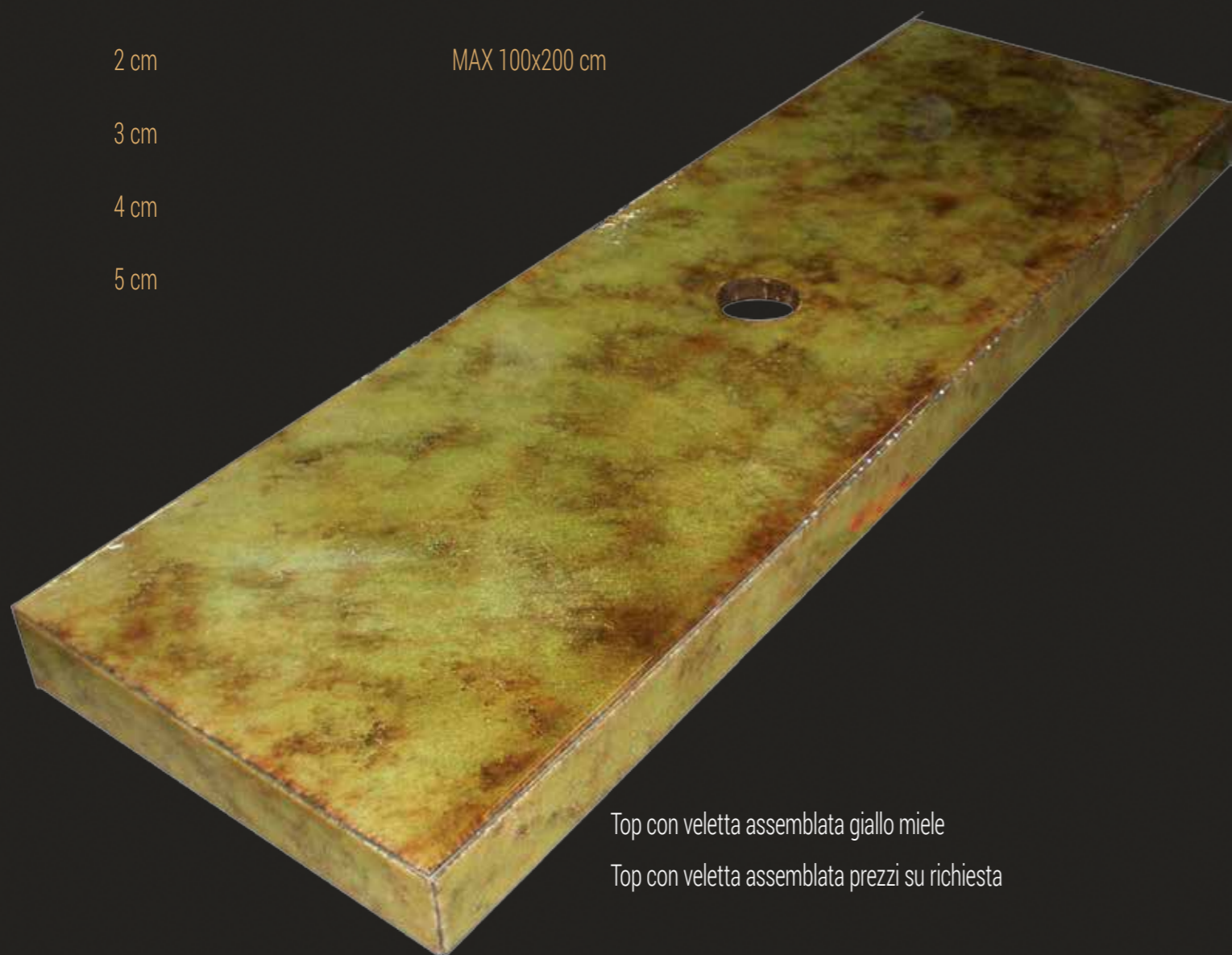

5 cm



Top con veletta assemblata giallo miele

Top con veletta assemblata prezzi su richiesta

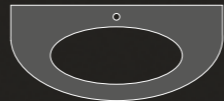
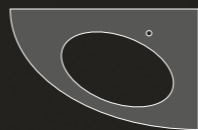
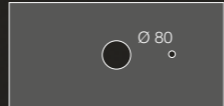
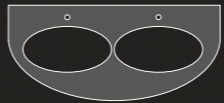
Galassia - Canaletto Top in pietra lavica sp.3cm

Modelli	Caratteristiche	Dimensioni	Peso
Gaia 	- Sp. 3 cm - Bordo Toro - Foro Lavabo ovale acquario - Foro Rubinetteria	60x120 - 3 cm Pr.111 pcs *	60 kg
		60x140 - 3 cm Pr.113 pcs *	70 kg
		60x160 - 3 cm Pr.117 pcs *	80 kg
		60x180 - 3 cm Pr.120 pcs *	90 kg
Appia Dx o Sx 	- Sp. 3 cm - Bordo Toro - Foro Lavabo ovale acquario - Foro Rubinetteria	60x120 - 3 cm Pr.108 pcs *	60 kg
		60x140 - 3 cm Pr.111 pcs *	70 kg
		60x160 - 3 cm Pr.115 pcs *	80 kg
		60x180 - 3 cm Pr.116 pcs *	90 kg
Mania 	- Sp. 3 cm - Bordo Retto - Foro Lavabo sottopiano - Foro Rubinetteria	50x120 - 3 cm Pr.106 pcs *	54 kg
		50x140 - 3 cm Pr.107 pcs *	63 kg
		50x160 - 3 cm Pr.111 pcs *	72 kg
		50x180 - 3 cm Pr.112 pcs *	81 kg
Gaia Twin 	- Sp. 3 cm - Bordo Toro - Foro Lavabo ovale sottopiano - 2 fori Rubinetteria	60x160 - 3 cm Pr.121 pcs*	40 kg
		60x180 - 3 cm Pr.123 pcs *	49 kg
		60x200 - 3 cm Pr.127 pcs *	55 kg
		60x210 - 3 cm Pr.130 pcs *	115 kg
Mania Twin 	- Sp. 3 cm - Bordo Retto - Foro Lavabo soprapiano - 2 fori Rubinetteria	50x160 - 3 cm Pr.114 pcs *	72 kg
		50x180 - 3 cm Pr.117 pcs *	81 kg
		50x200 - 3 cm Pr.120 pcs *	90 kg
		50x210 - 3 cm Pr.121 pcs *	95 kg

STAFFA per TOP - Support Bracket for Top

- Кронштейн к началу - Étrier de support pour le Top

Staffa profondità 40cm

Pr.81 pcs

in metallo cromato (chromed)

Pr.96 couple

Portasalviette per staffa

Pr.72 pcs

(Towel holder for bracket)

*spese di imballo e trasporto escluse

*cost for packing and transport are not included

*frais d'emballage et expédition non inclus

*расходы на упаковку и доставку не включены

Galassia - Canaletto - Canaletto⁺ Piatti doccia in pietra lavica

Piatti doccia su misura a preventivo

Showers plates made to measure quote

Душевые поддоны на заказ цитату

Bacs à douche sur mesure devis

SPESSORI

DIMENSIONI

THICKNESS

SIZE

2 cm

MAX 100x200 cm

3 cm

4 cm

5 cm

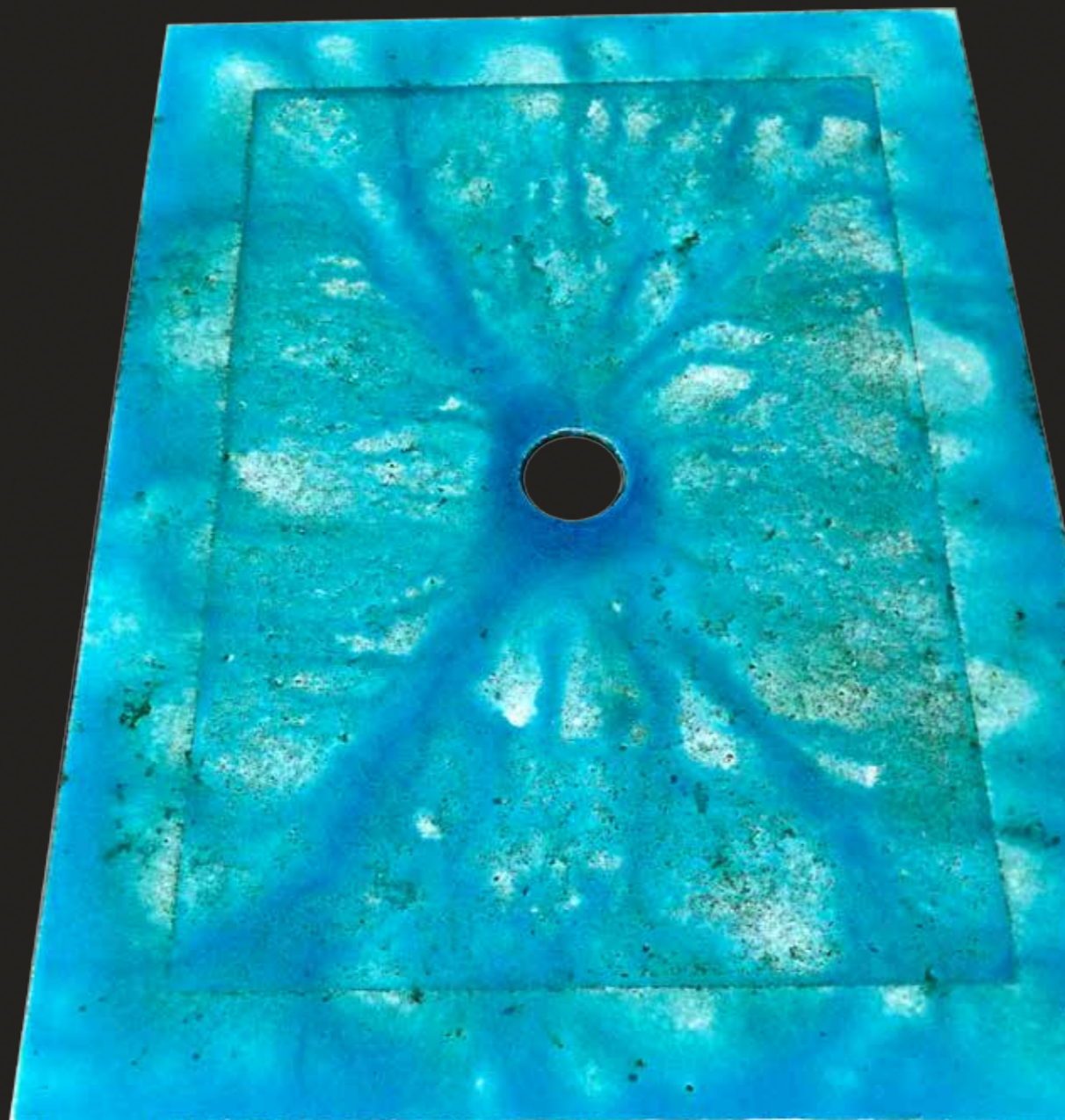

Galassia - Canaletto - Canaletto⁺ Piatti doccia sp.3cm

Modelli

Caratteristiche

Dimensioni

Peso

Modelli	Caratteristiche	Dimensioni	Peso
Ri-Quadro 	- Sp. 3 cm - Foro scarico centrale - Bocciardato	80x80 - 3 cm Pr.112 pcs *	55 Kg
		100x100 - 3 cm Pr.118 pcs *	86 Kg
		80x100 - 3 cm Pr.116 pcs *	72 Kg
		80x120 - 3 cm Pr.118 pcs *	86 Kg
		80x140 - 3 cm Pr.121 pcs *	101 Kg
In-Angolo 	- Sp. 3 cm - Bordo Retto - Bocciardato	80x80 - 3 cm Pr.112 pcs *	45 Kg
		100x100 - 3 cm Pr.114 pcs *	70 Kg
		80x100 - 3 cm Pr.113 pcs *	58 Kg
		80x120 - 3 cm Pr.114 pcs *	80 Kg
In-Tondo 	- Sp. 3 cm - Foro scarico centrale - Bocciardato	80x80 - 3 cm Pr.114 pcs *	50 Kg
		100x100 - 3 cm Pr.116 pcs *	80 Kg

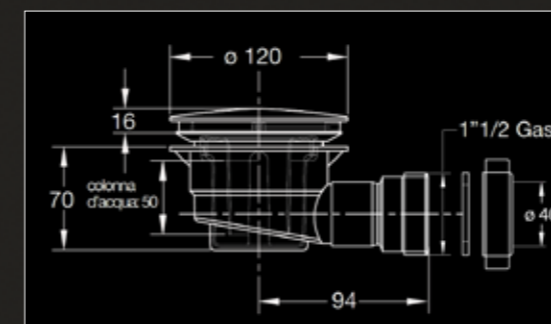

Sifone per doccia
Coperchio rivestita in acciaio 25
l/min inox ϕ 120 mm, scarico filettato
1"1/2 con ghiera

Prezzo su richiesta
Quotation under request

ABS cap covered with stainless steel
sheet ϕ 120 mm, threaded outlet
1"1/2 with nut

Prezzo su richiesta
Quotation under request

*imballo in cassa di legno
Упаковка в деревянная обрешетка

Packing in wooden crate
Emballage en caisse de bois

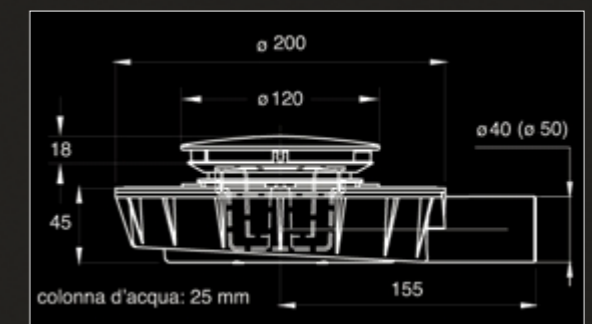

Sifone ribassato filo pavimento
Coperchio rivestito in acciaio inox 12
 ϕ 120 mm, scarico ϕ 50 mm maschio

Prezzo su richiesta
Quotation under request

ABS cap covered with stainless steel
sheet ϕ 120 mm, outlet ϕ 50 mm male

Prezzo su richiesta
Quotation under request

Galassia - Canaletto - Canaletto+ - Oro Venezia Specchi in pietra lavica

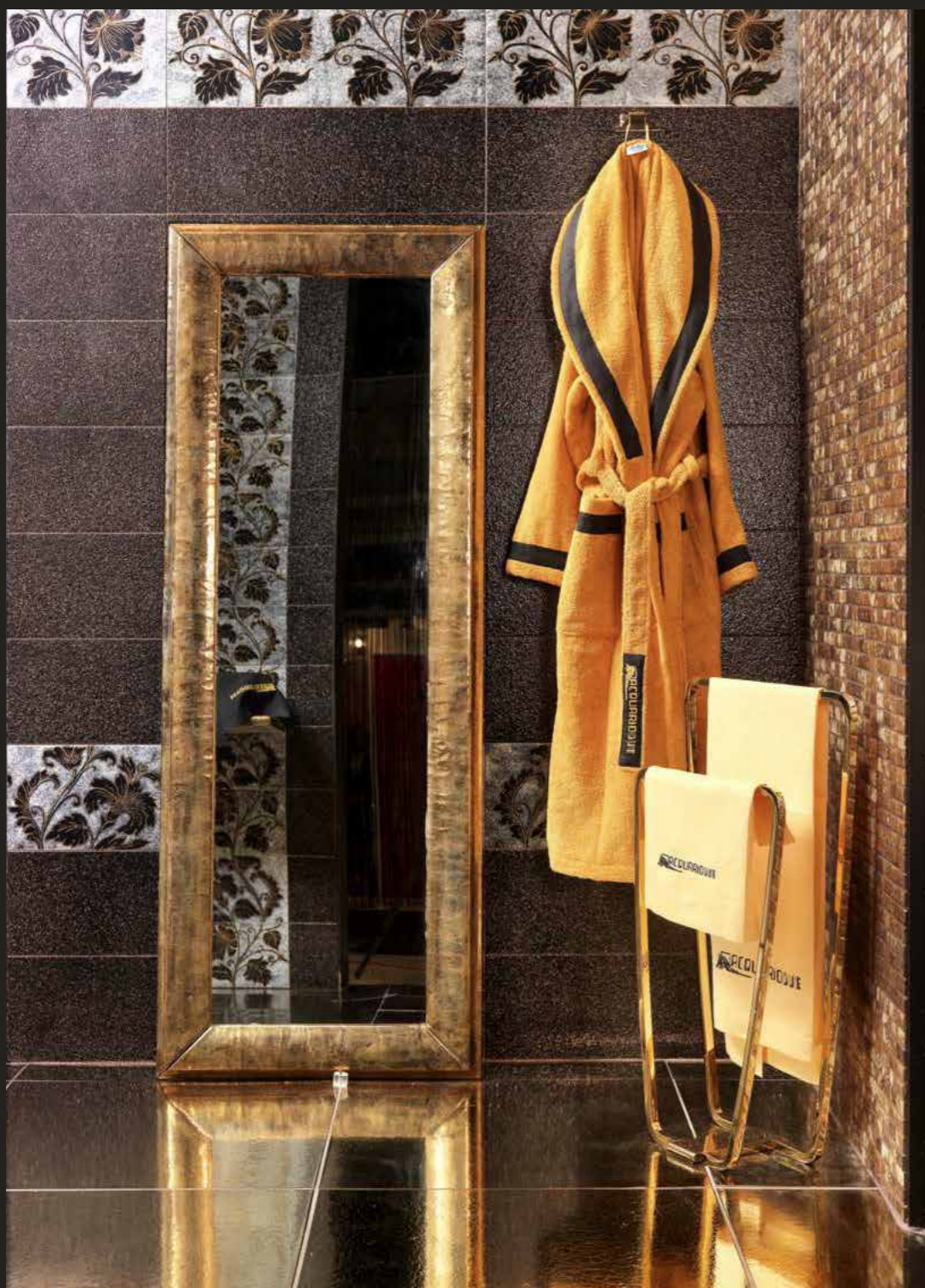

Modelli



Caratteristiche

A TERRA

- Sp.4 cm
- Cornice neoclassica
- finitura canaletto o galassia

A TERRA

- Sp.4 cm
- Cornice neoclassica
- finitura canaletto+

A TERRA

- Sp.4 cm
- Cornice neoclassica

A MURO

- Sp.4 cm
- Cornice neoclassica
- finitura Canaletto o Galassia
- Gancio posteriore

A MURO

- Sp.4 cm
- Cornice neoclassica
- finitura Canaletto+
- Gancio posteriore

A MURO

- Sp.4 cm
- Cornice neoclassica
- finitura Oro Venezia
- Gancio posteriore

Dimensioni

- 65x185 Pr.112 pcs

- 65x185 Pr.114 pcs

- 65x185 Pr.120 pcs

- 35x95 Pr.106 pcs
- 40x120 Pr.108 pcs
- 40x180 Pr.110 pcs

- 35x95 Pr.110 pcs
- 40x120 Pr.112 pcs
- 40x180 Pr.115 pcs

- 35x95 Pr.114 pcs
- 40x120 Pr.116 pcs
- 40x180 Pr.121 pcs

*imballo in cassa di legno

Упаковка в деревянная обрешетка

Packing in wooden crate

Emballage en caisse de bois

Grandi Lastre sp.2cm – Big Size Sp.2cm Canaletto o Galassia Canaletto+ Oro Venezia

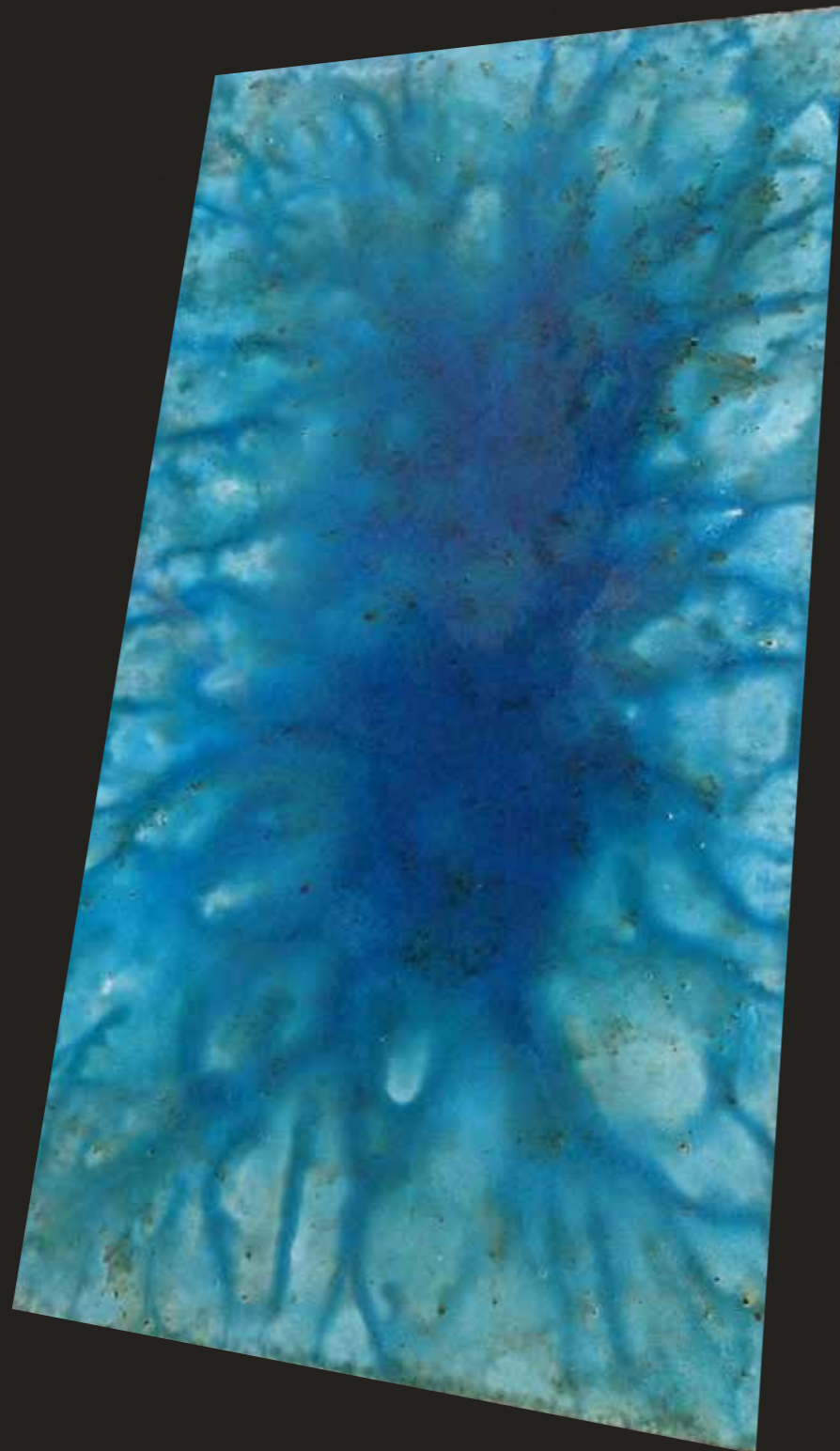
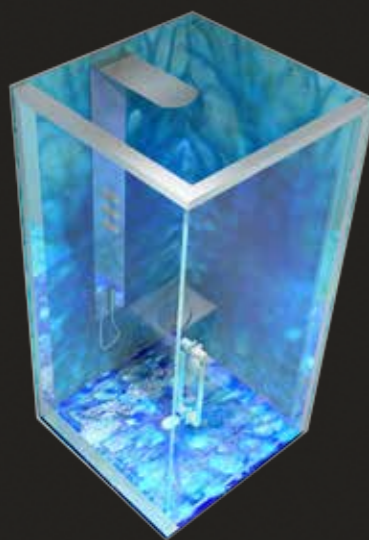

Modello	Dimensioni	Spessore	Codice	Peso	
Canaletto Galassia	20X200	sp 2 cm	Pr. 85 Pcs	Kg.27	
	40X200	sp 2 cm	Pr. 100 Pcs	Kg.51	
	50X200	sp 2 cm	Pr. 101 Pcs	Kg. 63	
	60X200	sp 2 cm	Pr. 103 Pcs	Kg. 75	
	- Pezzo unico	70x200	sp 2 cm	Pr. 108 Pcs	Kg. 87
	- Sp.2cm	80X200	sp 2 cm	Pr. 107 Pcs	Kg.99
	- Tutti i Colori	90X200	sp 2 cm	Pr. 108 Pcs	Kg.111
	100x200	sp 2 cm	Pr. 114 Pcs	Kg.123	

Canaletto+	20X200	sp 2 cm	Pr. 90 Pcs	Kg.27	
	40X200	sp 2 cm	Pr. 102 Pcs	Kg.51	
	50X200	sp 2 cm	Pr. 103 Pcs	Kg. 63	
	60X200	sp 2 cm	Pr. 105 Pcs	Kg. 75	
	- Pezzo unico	70x200	sp 2 cm	Pr. 107 Pcs	Kg. 87
	- Sp.2cm	80X200	sp 2 cm	Pr. 110 Pcs	Kg.99
	- Tutti i Colori	90X200	sp 2 cm	Pr. 111 Pcs	Kg.111
	100x200	sp 2 cm	Pr. 114 Pcs	Kg.123	

Oro Venezia	20X200	sp 2 cm	Pr. 95 Pcs	Kg.27	
	40X200	sp 2 cm	Pr. 103 Pcs	Kg.51	
	50X200	sp 2 cm	Pr. 106 Pcs	Kg. 63	
	60X200	sp 2 cm	Pr. 109 Pcs	Kg. 75	
	- Pezzo unico	70x200	sp 2 cm	Pr. 111 Pcs	Kg. 87
	- Sp.2cm	80X200	sp 2 cm	Pr. 114 Pcs	Kg.99
	- Tutti i Colori	90X200	sp 2 cm	Pr. 121 Pcs	Kg.111
	100x200	sp 2 cm	Pr. 127 Pcs	Kg.123	

Foro (su ordinazione)	Pr.57 Pcs	Lastra su misura (su preventivo)	*imballo in cassa di legno
Hole (on order)	Pr.57 Pcs	Slab non-standard (by quotation)	Packing in wooden crate
Отверстие (под заказ)	Pr.57 Pcs	Ластра нестандартные (с цитатой)	Упаковка в деревянная обрешетка
Trou (sous commande)	Pr.57 Pcs	Formats non standard (sur devis)	Emballage en caisse de bois

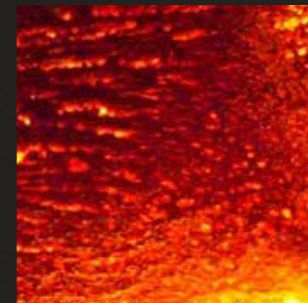
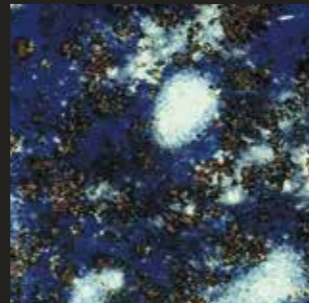
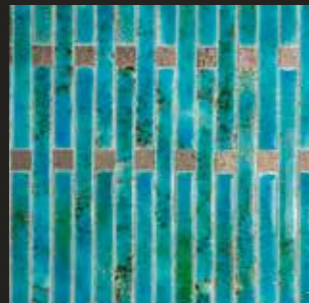
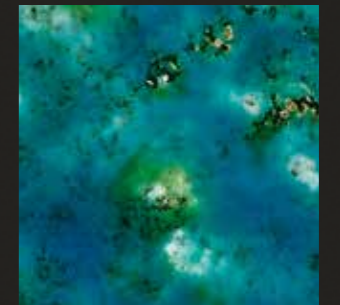
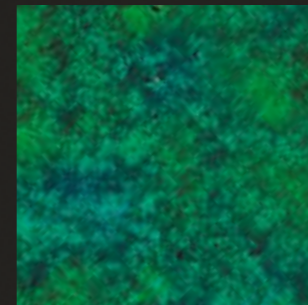
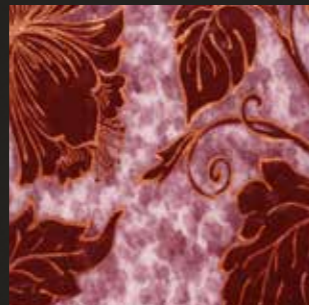
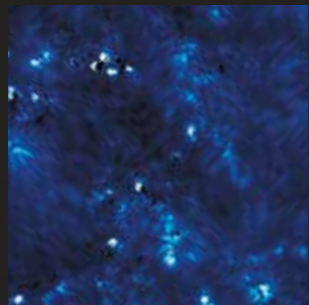
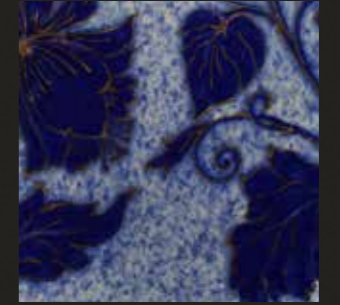
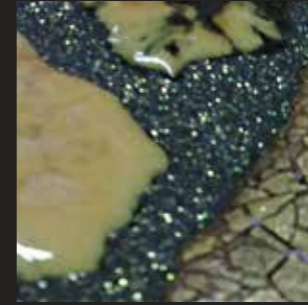
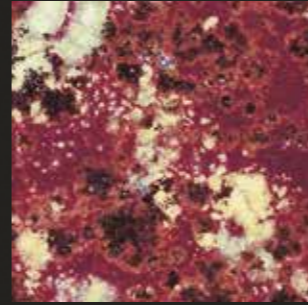
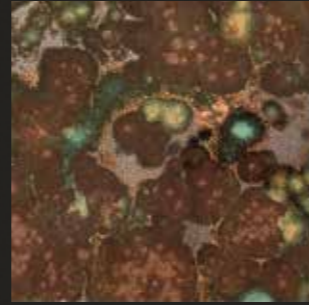
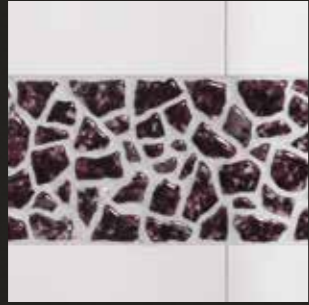

LAVA STONE

Kitchen - Bathroom - Wellness

SECOND EDITION

2017





© Acquario Due

via 1° maggio 31/33
35030 Bastia di Rovolon
Padova - Italy
+39 (049) 9910777
+39 (049) 9914101

info@acquarioceramiche.com
www.acquarioceramiche.com
www.facebook.com/AcquarioDue
www.twitter.com/AcquarioDue